



209 Citation Drive, Units 5 & 6
Concord, ON, Canada, L4K 2Y8
Telephone (905) 264-1414
Fax (905) 264-1147

E-mail: info@airmaxtechnologies.com
Web Site: www.airmaxtechnologies.com

MaxAir™ 50e, 70e, 100e P2 & P3 Zoned Mini Ducted Fan Coil Systems

Combination Heating/Cooling Equipment

Design, Installation and Maintenance Instructions

AirMax Technologies Mini Ducted MaxAir(e)™ fan coil systems

Important: Read and save these instructions.

Install in accordance with CEC and NEC; All wiring shall conform to CEC, NEC, and local building and electrical codes.



CERTIFIED
FAN COIL UNITS



LISTED
PLASTIC MATERIAL
Listed in accordance with CAN/ULC-S102.2
Mounted as single units or in pairs, minimum spacing
of 610 mm between units.
Flame Spread – 0 Smoke Developed - 70
Air Diffuser Assembly
Flame Spread – 0 Smoke Developed - 30
Elbow, Extender, Take-Off, Dust Cap, Click Connector

Table of Contents

INTRODUCTION	5
BENEFITS.....	5
APPLICATIONS.....	5
PRODUCT DESCRIPTION	6
CABINET	6
HEATING COILS.....	6
COOLING COILS	6
FAN.....	6
OFF SEASON CIRCULATION	6
WATER HEATER	6
BOILER	6
ACCESSORIES	6
CHECK VALVE.....	6
CIRCULATION PUMP	7
FLOW CONTROL VALVE.....	7
EQUIPMENT SELECTION AND SIZING	7
SELECTING THE NUMBER OF DIFFUSERS.....	7
EXAMPLE	8
DIFFERENCE IN THE NUMBER OF DIFFUSERS NEEDED FOR HEATING & COOLING	9
DIFFUSER DESIGN NOTES	9
TRUNK DUCT DESIGN NOTES	9
ELBOW AND TEE DESIGN NOTES	10
BRANCH DUCT DESIGN NOTES.....	10
SELECTING THE FAN COIL	10
RETURN DUCT DESIGN NOTES.....	10
INDOOR AIR QUALITY	11
COMBINATION MAXAIR FAN COILS AND HYDRONIC HEATING	11
LOW WATER TEMPERATURE SYSTEMS.....	12
INSTALLATION	12
AIR HANDLER MOUNTING	12
DOMESTIC WATER PIPING	12
ANTI-SCALD VALVE.....	13
COOLING COIL & TX VALVE.....	13
WATER HEATER/BOILER.....	14
DUCTWORK	14
DIFFUSER LOCATION	14
FAN COIL PLACEMENT	14
TRUCK DUCT	15
TRUCK DUCT CONNECTIONS	15
ELBOW AND TEE PLACEMENT	15
CONNECTING THE DUCTS TO THE FAN COILS.....	15
BRANCH DUCTWORK	15
CONNECTING THE 2 1/2" BRANCH DUCT TO THE TRUNK DUCT.....	16

BRANCH DUCT TERMINATION.....	17
INSTALLING THE DIFFUSERS.....	17
AIRFLOW.....	17
RETURN AIR DUCT.....	17
CONDENSATION.....	17
DX REFRIGERANT COOLING.....	18
CONDENSING UNIT.....	18
ANTI-ICE CONTROL AND TX VALVE.....	18
EVAPORATOR COIL ASSEMBLY.....	19
REFRIGERATION PIPING.....	19
CONDENSING UNIT WIRING.....	19
EVACUATING AND CHARGING.....	19
ELECTRICAL (MAXe UNITS) .	20
DCC7235 LAYOUT AND CONNECTIONS.....	20
POWER INPUT.....	21
CONTROL SYSTEM INPUTS.....	21
OUTPUTS.....	22
OUTPUTS WITH DIP SWITCH.....	24
TYPICAL HOOK UP.....	28
DIMENSIONS AND MOUNTING.....	28
START-UP PROCEDURES	28
UNDERSTANDING THE ZONE CONTROLS	29
USING THE ZONE CONTROLS WITH MULTI-STAGE EQUIPMENT	30
UNDERSTANDING THE ZONE CONTROLLER DISPLAY	31
CONFIGURING THE ZONE PANEL	33
ADDITIONAL FEATURES OF THE 3 ZONE PANEL	34
2 AND 3 ZONE PANEL CHECKOUT	35
SEQUENCE OF OPERATION P2	35
SEQUENCE OF OPERATION P3	36
SERVICE AND MAINTENANCE	37
FILTER.....	37
DUCT CLEANING.....	37
COILS.....	37
AIR CONDITIONING COIL.....	37
FAN AND MOTOR.....	37
EXTERNAL PUMP.....	37
TROUBLESHOOTING	38
EXTERNAL PUMP DOES NOT RUN.....	38
EXTERNAL PUMP IS NOISY AT START-UP.....	38

WATER HEATER T&P IS WEEPING.....	38
INSUFFICIENT OR NO HEAT.....	38
COLD WATER AT HOT FAUCET	38
FAN RUNS FOR COOLING BUT NOT HEATING	38
HEATING DURING OFF CYCLE	38
ZONE SYSTEM TROUBLESHOOTING	39
ZONE SYSTEM CHECKS.....	39
2 ZONE PANEL TROUBLESHOOTING STEPS.....	39
3 ZONE PANEL TROUBLESHOOTING STEPS.....	40
WIRING DIAGRAM (P2 UNITS)	42
WIRING DIAGRAM (P3 UNITS)	43
WIRING DIAGRAM (P3 UNITS)	44
WIRING DIAGRAM (P3 UNITS)	45
ZONE SYSTEM APPLIED WITH A HEAT PUMP CONDENSING UNIT	46
TWO ZONE SYSTEM.....	46
THREE ZONE SYSTEM.....	46
HEATING SEQUENCE OF OPERATION	46
FAN COIL DIMENSIONS AND RETURN AIR SIZE AND LOCATION	50
EVAPORATOR COIL SIZES	56
50/70/100 COOLING COIL FILTER FRAME CABINET	57
SAMPLE PIPING SCHEMATICS	58
TERMS AND CONDITIONS OF SALE	62
WARRANTY REGISTRATION	63
WARRANTY PARTS REQUEST	64

INTRODUCTION

The **MaxAir(e)**TM line of combo air handlers is specifically designed for use in residential and commercial combination space and water heating systems (Combo Systems). Combo heating systems use the home's water heater or boiler to provide both space heating and domestic hot water, eliminating the need for a furnace.

Combo heating systems are ideally suited for single family homes, townhouses and apartments where the use of a furnace may not be feasible or where space requirements are limited. They can also be used for additions, renovations, and finished basements as a replacement for, or in addition to the existing heating system. Our air handlers are the smallest units available in their capacity range.

The **MaxAir(e)**TM line of air handlers are designed to take the guess work out of system sizing and installation. Matched specifically to common water heater and boiler sizes, our air handlers can be quickly sized using the quick sizing information in our **Equipment Sizing Manual**. For applications requiring special consideration, our detailed sizing method gives you the ability to size the air handler to ANY operating condition. Call for answers to any questions related to sizing, installation or trouble-shooting for any of our air handlers or water heaters.

We provide you with the quietest operating air handler available. By using large capacity, high output heating coils, our product delivers more heating per volume of air than any of our competitors, which means warmer delivered air temperatures. Our blower fans are also the widest available in their size range, which translates into slower fan speeds to deliver the same amount of air. All

these features add up to warmer, more comfortable air, quiet operation, and a satisfied customer.

Water heaters, boilers and air handlers can be purchased from a wholesale supplier, rented from your Gas Utility, or purchased from **Airmax Technologies** as part of a complete heating package.

Benefits of the MaxAir(e)TM Mini Ducted systems are:

- Vents can be located in low traffic areas on the floor, walls, or ceiling, or in a kick space.
- A HVAC tradesman can install a system using these design and installation instructions.
- Small diameter supply ducts eliminate the need for large sheet metal ducting and allows smaller bulkheads.
- Can be installed in existing structures with minimal structural changes.
- Provides a quiet, draft free environment.

MaxAir(e)TM Mini Ducted systems applications:

- Retrofit construction to add heating, cooling, humidification, or filtration to a building.
- New construction to deliver air throughout the entire building envelope (eg. services 3 story townhouses more effectively than conventional furnaces).
- New and retrofit construction to reduce bulkhead sizes required for duct work.

PRODUCT DESCRIPTION

cabinet

All cabinet panels are insulated and have a tough, durable low maintenance galvanized finish inside and out for extra long life.

The air handler can be suspended with 4 resilient hanging straps. Hanging straps can be secured at all corners, using existing screw locations without fear of damaging internal components.

Cabinet dimensions are designed to provide maximum installation flexibility. Refer to installation requirements for more details.

heating coils

All heating coils are potable water grade copper suitable for use in plumbing systems. No lead solder is used in any component construction. All coils and internal piping conform to ASTM B68 or ASTM B88 standards.

High density aluminum fins provide maximum heat transfer for small coil surface. Lower air flow and higher fin density equals warmer, more comfortable air with much less fan noise than other air handlers.

cooling coils

All Airmax accessory slab cooling coils are shipped with the liquid and suction lines piped to the exterior of the unit casing. A TX valve where included, is shipped installed.

High density aluminum fins provide maximum heat transfer for minimal coil surface. Coils are sized for low face velocities to prevent carry over and the galvanized unit drain pans are below the entire coil including the return bends and suction header.

fan (e unit)

Variable speed motors allow for discrete and selectable speeds for heating, cooling, and continuous fan, providing the installer or home owner maximum choice of options.

off-season circulation

An off-season circulation cycle is included on the air handler to provide periodic circulation of water through the space heating loop during periods of infrequent use.

water heater

Any properly sized gas, propane, or oil fired water heater will work in a combo heating system. Make sure the water heater being used is approved for combo applications. (Most manufacturers' heaters are approved.) Warranties are typically not affected by using a water heater in combo applications.

boiler

All **Airmax Technologies** combo air handlers are compatible for use with boilers or instantaneous water heaters. Contact your Airmax Technologies representative for specific installation details.

ACCESSORIES

check valve

Check valves serve two purposes:

- protect against back-flow of water to avoid short circuiting around the water heater during domestic water use.
- protect against thermal siphoning.

Thermal siphoning is flow of water through the space heating circuit while the circulating pump is not operating due to hot water rising by natural convection. This phenomenon is of little consequence during winter months, but during the summer this will cause overheating, interfere with air conditioning, and waste energy. The check valve is supplied an integral part of the circulating pump.

circulating pump

Air handlers come with external, field installed pumps, for flexibility and service. The circulating pump is matched for maximum performance for combo use utilizing a storage type water heater. Contact your Airmax representative for applications other than storage tanks.

flow control valve

An adjustable flow control valve is recommended to optimize system performance and ensure that the output from the water heater is stable. Any throttling type valve may be used, but for convenience, **AirMax** can include a valve, at additional cost, with each air handler for field installation.

Combo heating systems function poorly if the temperature drop through the air handler's coil is not maintained between 20-30°F (11-17°C). The only way to adjust the water temperature drop through the coil to match the rated output conditions of the coil is to adjust the flow of water.

The performance relationship between the air handler and the water heater is ignored by most manufacturers. The **MaxAir(e)**TM combo fan coil system has been specifically designed to optimize the output of the water heater to which the air handler is attached.

- If the temperature drop is less than 20°F (11°C), the system has an excessive flow rate. This will cause turbulent mixing within the water heater storage tank, reducing the domestic water capacity, and creating large fluctuations in delivered water temperature.
- If the temperature drop across the heating circuit is greater than 30-40°F (17-22°C) there is inadequate flow. This will cause poor heating performance of the air handler and can cause stacking of the water heater leading to unsafe water delivery temperatures for domestic use.

EQUIPMENT SELECTION AND SIZING

This section of the manual is to assist the designer of the **MaxAir**TM Mini Ducted Combo fan Coil System in the quantity and placement of outlets, the size and location of the supply duct, and the size and location of the fan coil. To size a **MaxAir**TM system for a residence, it is necessary to have an accurate heat loss/gain done for the structure in order to eliminate improper sizing.

After completing the room by room load calculations, select the **MaxAir**TM model unit that will properly meet the load requirements.

selecting the number of diffusers

From the recommended number of diffusers indicated in Table 1, determine the number of diffusers needed. It is recommended that you ***design for the median number of diffusers***. This will yield favorable system noise levels and minimize potential nuisance equipment failures. ***If a cooling coil is to be included always design for at least the median number of diffusers.***

Table 1 Recommended Number of Diffusers

Model	MaxAir 50e P2 & P3		MaxAir 70e P2 & P3		MaxAir 100e P2 & P3	
Btuh Heating @180°F E.W.T.	55,649		77,981		98,593	
Btuh Heating @170°F E.W.T.	49,971		69,804		89,630	
Btuh Heating @160°F E.W.T.	44,700		58,902		80,666	
Btuh Heating @150°F E.W.T.	39,086		50,519		71,704	
Btuh Heating @140°F E.W.T.	35,195		46,278		62,741	
Btuh Heating @130°F E.W.T.	30,250		41,000		53,500	
DX Cooling (Tons) (1)	1 to 2		2 to 2 ½		2 ½ to 3	
C.F.M. @ 1.5" E.S.P.	580		750		950	
HP-RPM (e)	1/2-1,800		3/4-1,800		1.0-1,800	
HP-RPM (PSC)	1/2-1,625		3/4-1,625		3/4-1,625	
FL Amps @ 120/1/60 (e)	7.7		9.9		11.6	
FL Amps @ 120/1/60 (PSC)	6.9		9.5		9.5	
G.P.M. Flow rating	5		7		8	
Fan Coil Size (L/W/H)	36"x14"x18 1/2"		43"x19 1/2"x18"		36"x25 1/2"x18"	
Supply Air Connections P2	2 x 8"		2 x 8"		2 x 8"	
Supply Air Connections P3	1 x 8", 2 x 6"		2 x 8", 1 x 6"		2 x 8", 1 x 6"	
Return Air Size Required	12" x 14" min.		16" x 15" min.		16" x 16" min.	
Minimum Outlets (2)	10(3)		16(3)		22(3)	
Minimum Outlets (per zone)	6	4	9	6	12	8
Maximum Outlets (per zone)	9	6	10	7	14	10
Maximum Outlets	P2 P3		P2 P3		P2 P3	

(1) Smaller condensers maybe matched to fan coil when required (match TXV to condenser size)

(2) The median number of outlets should be used to achieve maximum DX cooling capacity for each model size. Eg. If 2 ½ tons are required in a Max 70 system you must use minimum 20 outlets.

Heating capacity based on 70°F return air, high speed, 10' duct length per branch and no cooling.

(3) Contact factory for minimum number of outlets if using less than maximum DX cooling capacity.

Divide the chosen number of diffusers into the building load and this will give the capacity per diffuser. Referring back to the building heat loss you can divide the total heat load per zone by the capacity per diffuser, giving you the quantity of outlets needed per room.

example

Fan coil model: MaxAir 50e P2 with 180°F water
 Building heat loss: 51,000 BTUH
 Building heat gain: 18,000 BTUH
 Number of outlets: 17
 Cooling coil: 1.5 tons
 Heating coil: 55,649 BTUH

Calculation:

55,649 btuh/17= 3,273 btuh/outlet (heating)

and

18,000 btuh/17= 1,058 btuh/outlet (cooling)

If a room has a heat loss of 4,500 btuh and a heat gain of 2,400 btuh, 3 diffusers are required.

difference in number of diffuserers needed for heating and cooling

There may be cases in which the number of outlets needed for heating may be significantly different than the amount needed to meet the cooling load for the room. If this

happens, then you will have to take the greater number of outlets to provide both heating and cooling for the room. If there is a large difference in the number of diffusers required for heating and cooling, then vents can be opened or closed to provide summer/winter adjustment.

diffuser design notes

Unlike conventional systems it is not necessary to locate **MaxAir™** diffusers above/below windows or to center diffusers along an exterior wall length. Diffusers can be located on interior walls if necessary but if possible keep them closer to exterior walls for maximum occupant comfort.

Air from the diffuser is introduced into the room at a high velocity. This creates a venturi effect at the diffuser. This negative pressure draws room air into the conditioned air stream and mixes and distributes both air streams together. This phenomenon constantly stirs the room air and prevents stratification and stale air accumulation.

It is preferred to locate the diffusers in low traffic areas of the room to be conditioning. Diffusers should be located at least 8 inches (to center of diffuser from finished surface) from walls and should not be located near curtains or wall coverings that will be affected by the high velocity air stream. The diffusers should not be located under furniture or near obstructions that will nullify the mixing effect that the diffusers are designed to accomplish. In kitchens or bathrooms where it may not be desirable to locate a diffuser on the floor the diffusers can be located in a kick space or on the wall and discharge the air horizontally. In a kick space the diffuser may have to be trimmed to fit properly. In the bathroom do not locate in an area that will cause a draft on people entering or leaving a bath or shower.

trunk duct design notes

The location of the main trunk duct will be determined by the structural design of the

building. One of the main goals in laying out the trunk duct is to achieve a self-balancing system.

A common location for the horizontal trunk duct is along the main structural support beam, at the center of the building in the basement, and at right angles to the floor joists. This will yield the shortest and most equidistant 2 ½" branch runs as possible. Utilizing this layout will provide a self-balancing system for the main floor and basement.

A common location for the vertical trunk duct on a two storey building is in a closet or furred wall as close to the building center as possible. This will allow the second floor horizontal trunk duct, (located in the attic) run at the building center line, to be divided 50/50, front to back, with equidistant branch run lengths, to again be self balancing for the second floor. Where the **MaxAir™** fan coil unit has two trunk ducts ensure the trunk ducts are as close as possible in equivalent length.

For trunk duct runs it is recommended that the duct be insulated to prevent supply air temperature losses/gains. Where the trunk duct is run through unconditioned spaces the duct must be insulated and provided with a vapor barrier to meet the local code requirements. In unheated attics the trunk duct should be laid on the ceiling joists, insulated and provided with vapor barrier, then the attic insulation should be laid over top of the duct to further reduce duct losses/gains. In conditioned spaces and if the trunk duct is less than 25% of the maximum allowable trunk duct length (Table 2) the duct can be left un-insulated.

If the trunk duct approaches the maximum allowable length additional branch ducts may be necessary to compensate for main duct pressure and temperature losses/gains.

Connection sizes for the different cabinet sizes are 6 & 8". It is recommended that the trunk duct be started at 6" or 8" diameter

minimum even if a smaller diameter duct will handle the design number of outlets. After 30' in length the duct can be reduced in size if required (reduce at a rate of one size per 10' length maximum).

Table 2 Maximum Allowable Trunk Duct Length

Duct Size	Maximum Length	No. of Take Offs
4"	20'	2
5"	30'	4
6"	50'	10
7"	60'	16
8"	70'	20
10"	100'	28

elbow and tee design notes

It is recommended that you avoid immediate disturbances in the airflow for at least 18" from the plenum. If possible allow 18" before installing any tee, or saddle. Adjustable elbows can be incorporated. Avoid installing saddles within 18" from the unit discharge unless all saddles are to be located within close proximity to the unit. When utilizing tees that deflect both air streams at 90° angles maintain a 50/50 split on the air stream. When using tees that deflect one air stream at 90° maintain a 70% straight through to 30% at right angle ratio. These are approximate ratios plus/minus 10%.

branch duct design notes

Branch duct runs should be kept at the same length and approximately 10' long. Adjustable dampers are included with the diffusers to compensate for different duct lengths. The minimum branch duct run is 5' and the maximum recommended where possible is 15'. When longer runs are utilized the airflow and the BTU delivery is reduced. In an attempt to compensate for long duct lengths use Table 3 to determine the correction factor for losses on long branch duct lengths.

Table 3 Branch Duct Correction Factors

Branch duct length	10'	15'	20'
Correction multiplier (insulated)	0	.90	.75

To the btuh capacity per diffuser determined earlier and based on the length of branch duct required between the trunk duct and the diffuser apply the above multiplier to determine the corrected btuh capacity per diffuser. This correction applies to both heating and cooling capacities. Should additional branch ducts be required in certain zones consult Airmax Technologies before adding them. ***Do not run un-insulated duct in unconditioned spaces.***

selecting the fan coil

Once the heat load and the corrected number of outlets required is known for the job you can then finalize the model of the **MaxAir™** fan coil(s) you need.

return air duct design notes

The return air is to be sized as per local building codes and good practices. Take note of the reduced CFM of the units, compared to standard heating and cooling equipment. The return air is to be sized on a 0.15" w.g. as compared to 0.10" w.g. on conventional air systems. It is good design practice to line the first five feet of the return air duct with a sound acoustic insulation. This will reduce sound transfer through the duct and operating sound levels. The maximum length for an individual return air duct is fifty feet.

It is recommended to install a grill which is 10-20% larger than the return duct area to ensure adequate free area and no velocity noise at the grill. Where allowed by local codes, a single return air grill may be used. When using flexible duct for return air, use one size larger duct due to the higher friction loss.

For areas that require fresh air make-up (either direct or through an ERV or HRV), an intake may be installed in the system. Size

and insulate the fresh air supply as per local code. Remember, should you install a duct that is too large, the excess fresh air will increase the system operating cost and effect overall equipment capabilities. It is recommended to install a well fitted damper into the return air plenum. The damper can then be adjusted to supply the exact amount of fresh air needed to meet local building codes. Optionally, a smaller diameter fresh air duct can be used and sized for a 0.15" w.g. pressure drop.

indoor air quality

The main factors of indoor air quality are air filtration, humidity control, and fresh make-up air. All of these factors can best be achieved with a continuous run fan system. It is important to have a good quality air filter for your **MaxAir™** fan coil system. Maintaining a clean air filter will increase the unit life span, allow the unit to operate efficiently and effectively, and will provide clean air for the occupants.

Humidity control is also an important factor to indoor air quality. Too much humidity can result in problems with bacteria, fungi, and mites. Too little humidity can result in respiratory problems, allergies, and asthma. An RH level of 35 - 45% is recommended. When a drum, power mist, or curtain flow type humidifier is used, the humidifier must be mounted on the return air duct and transitioned to a 2 ½" branch run to the plenum. Make certain the opening in the supply air plenum is no larger than 1".

When installing a steam humidifier special attention is required when installing the discharge hose. Although the humidifier installation manual may state that the discharge hose is to be mounted in the supply air plenum, this is not be the case in the **MaxAir™** fan coil system. The discharge hose must be mounted in the return air plenum. The reason for this is because the high static pressure in the supply plenum is greater than that found in the discharge hose

and will not allow the steam to exit the hose. Even in areas where there is no building code requirement for fresh air make-up, it is recommended to install a fresh air duct. In airtight buildings, the off-gassing of VOC's (volatile organic compounds) from building materials can be detrimental to the indoor air quality.

combination MaxAir™ and hydronic heating

One of the benefits of using a hydronic system is the versatility that you have when designing the heating system. Radiant underfloor heating is an excellent system, but it does have limitations. You cannot have cooling, air filtration, and humidification with a radiant heating system. Similarly, a **MaxAir™** system may not be an option for a house with high localized heat losses/gains.

For example, a room in a house with large window and very little insulation. Retrofitted radiant floor heating may be unable to meet the BTU requirements to heat the room. With a **MaxAir™** combo fan coil we can heat this room, but would have an excessive number of outlets in a small area.

It is in rooms such as this that a hybrid system of both radiant heating and a **MaxAir™** fan coil would be the optimum system to provide comfort conditioning. This will provide the homeowner with good indoor air quality, and warm floor comfort.

One of the most common approaches to heating with a hybrid system is using the **MaxAir™** fan coil to provide the comfort conditioning for the main floor (and second floor if applicable) and radiant tubing in the basement and tile areas. A few outlets located in the basement is recommended in order to provide good air circulation and supplementary heating if required.

low water temperature systems (combo systems with conventional hot water tanks + geothermal sytems)

Operating **MaxAir™** fan coils in a low temperature system, care must be taken when designing and installing the system. Due to the lower air temperatures, when installing ductwork in an unconditioned space, extra insulation is recommended in order to maintain a consistent air temperature at the outlets. The main supply plenum must be insulated and wrapped with a vapor barrier in order to meet local codes. All duct work should then be covered with another layer of insulation. Due to the fact that with lower water temperatures you get a lower supply air temperature, it is imperative that the water temperature is known at the design

stage. If possible, a higher tank setting should be used, and an anti-scald valve be installed for the domestic use. The higher water temperature will increase system capacity, and the anti-scald valve will reduce the risk of scalding. Since some areas have specific regulations regarding combo systems, check your local building code for details on water tank temperatures, tempering valves, and pump timers.

cooling coil capacities

Possible cooling coil capacities are given in the Table 1.

INSTALLATION

The installer must adhere strictly to all local and national code requirements pertaining to the installation of this equipment.

Detailed instructions are shipped with all accessory items and should also be followed in detail.

air handler mounting

The **MaxAir(e)™** combo air handler can be installed in most configurations. Some precautions must be observed for some of the possible mounting positions.

For installations where the access door faces up or down ensure the external circulating pump is not mounted with its shaft in the vertical position. The pump shaft must be mounted horizontally to avoid damage during operation.

The air handler can be mounted by securing straps through any of the existing screw holes in the cabinet. Should the existing screw be too short for securing a mounting strap, a longer screw can be used provided care is taken not to damage any internal components.

When fastening straps using screws, special care should be taken in the vicinity of the coil to avoid tube puncture.

The cabinet is designed so that the return air can be located on either side of the cabinet, through the bottom of the cabinet, or from the back. Position the filter rack so that the filter is readily accessible.

Install the air handler with the door firmly screwed in place to make certain the cabinet is mounted without racking. Provide at least 24 inches of service access clearance in front of the access panel of the air handler. zero clearance is acceptable on all other faces.

domestic water piping

Install a ½" (12mm) sediment faucet for use as a drain/purge valve. The drain valve must be located downstream of the pump and check valve, and upstream of the isolation valve (if isolation valve is present). This arrangement will allow any air trapped in the system to be easily flushed out. Follow the instructions in the *Start-up & Troubleshooting* sections.

Isolation valves are recommended, but not required. Installing isolation valves facilitates easy servicing and ensures positive purging of the system during start-up.

The isolation valves, if installed in the system should not be used as a throttling valve.

All joints in copper pipe must be lead free solder. All piping must be suitable for potable water use. All pipe & pipe connections shall comply with local building codes.

When soldering, special care should be taken to not overheat the water connections on the unit. Use a wet rag or heat absorption compound to prevent excessive heat buildup.

Maximum pipe lengths for all **MaxAir(e)**TM combo air handlers can be calculated using the information in the Design Manual.

When both top and side connections are provided on the water heater, recommendations of the manufacturer or supplier should be followed regarding connection.

When the space heating loop connections are made to the domestic water connections:

- the heating loop connections should be positioned horizontally in a vertical section of the domestic water line for both inlet and outlet. Refer to the suggested piping schematic for details.
- connect the heating loop to the domestic water connections as close to the water heater as possible.

Avoid sections of pipe in the heating loop that can trap air where possible.

It is usually impossible to install a system without having at least one part of the system or heating coil able to trap air. This will not be a problem if the connection to the domestic water lines is made properly, and the system is properly purged on set-up:

- The circulating pump is capable of removing small amounts of entrained air from the heating loop.
- Following the flushing procedures in the *Start-up* section will ensure that there is no air in the system after initial set-up.
- Proper connections between the domestic water lines and the heating loop will ensure that any air that collects in the water tank, does not make its way into the heating loop.

Inclusion of air bleed valves at high points of the heating system can be included but are to be specified by the plumbing designer.

anti-scald valve

Anti-scald valves are not required for normal operation, but may be used for installations where local codes dictate a lower domestic water temperature. If an anti-scald device is to be installed, it must comply with ASSE standards no. 1016 and 1017, where applicable.

cooling coil & TX valve

The Airmax accessory slab cooling coil is shipped loose. A factory installed TX valve where applicable, is shipped with the cooling coil. The TX valve is installed onto the distributor and an external equalizing line is piped into the suction line. Detailed instructions on the TX valve and the location of the external equalizing line and sensing bulb are available from your **MaxAir**TM dealer.

When brazing care should be taken to not overheat the connections on the coil. Use a wet rag or heat absorption compound to prevent excessive heat buildup.

Once the brazed connections cool down, apply a bead of silicone sealant to the copper pipes where they pass through the rubber grommet. This will prevent air leaks and air noise.

The **MaxAir(e)**TM fan coils with the accessory external cooling coil option are a draw through design. The drain pans have to be trapped to avoid air losses. The proper height of the trap is 2 times the internal static in the unit casing. For most applications a trap height of 3" is acceptable. This is the minimum distance between the trap outlet and the bottom of the trap. The trap inlet should be higher than the outlet to allow for proper drainage.

Important: Fill trap with water before running

the unit.

It is acceptable to vent the trap in situations with insufficient height and clearance.

In applications where a fan or motor body block the cooling coil face a space should be left between the cooling coil discharge face and the fan coil to avoid excessive and uneven coil velocity.

water heater/boiler

Follow the water heater manufacturer's instructions for installation and start-up of the water heater. Make sure the water heater is turned off during air handler installation and service. Ensure the water heater has been refilled, and all air is purged from the system before turning on the water heater.

duct work

To minimize fan noise in the living space, it is recommended that the first five feet of return air duct be lined with acoustic insulation, when the duct directly communicates with the living space.

Return and supply air duct work should be the same size as the air handler openings up to the first branch, fitting or transition.

Warning! Special care should be taken in the vicinity of the coil to avoid tube puncture. Screw into opening flange instead of top of cabinet when fastening the supply air duct.

Engineered duct design guidelines are based on a nominal external static pressure of 1.2" wc.

diffuser location

Please refer to the duct layout that has been done for the installation. This layout has been designed to provide you with the maximum benefit from your system. Small deviations may be necessary due to existing construction. However, if large deviations must be made, for example:

- Elimination of a diffuser from a room
- Moving a diffuser more than 10 feet from

its specified location

- Re-routing the main plenum

Contact your system designer before proceeding.

It is recommended to locate the diffusers at 8" on center from finished walls or corners and away from drapes or other wall coverings where construction type allows.

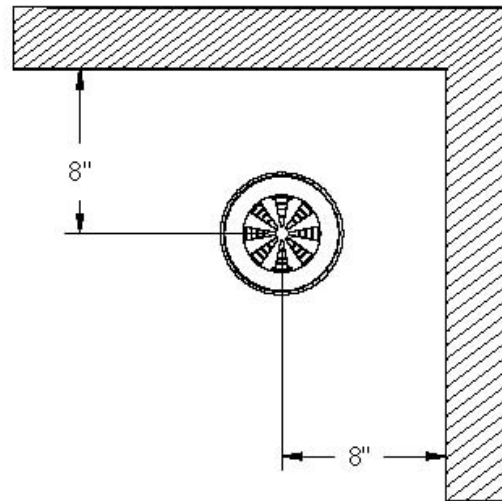

Using a 4½" hole saw, cut a hole into the floor, ceiling or wall to allow the elbow flange to fit through the hole. Secure the elbow flange to the floor, ceiling or wall with screws.

fan coil placement

The **MaxAir(e)**TM fan coil unit is to be placed according to the layout supplied by the designer. If a change in location is required, the person responsible for the design is to be consulted. The fan coil unit can be located in a horizontal or vertical position.

The location of the fan coil is not as critical as it is with conventional low velocity systems.

Location of the fan coil unit will depend on:

- Minimizing all duct runs.
- Maximizing usable floor space.
- Reducing structural changes.
- Serviceability and access to the unit.
- Location of heat/cool source to fan coil.
- Available space in mechanical room.

When suspending the unit from the ceiling, it is recommended to use spring vibration isolators at each corner of the fan coil unit. This will provide a secure means of hanging the unit, and will also reduce any transfer of vibration into the building structure. Rubber belting is also acceptable. Another common means of suspending the fan coil is with angle iron, sheet metal channel, or uni-strut placed underneath the unit, and supported by threaded rod. If this method is used, isolators (rubber or equivalent) must be placed between the fan coil unit, and the support.

Ensure that the hanging method does not hinder any piping, electrical runs, filter access, or blower access.

trunk duct

Inspect the location for the trunk duct as per the duct layout for the home or building. An important consideration in placement of the main supply plenum is that the fan coil unit must be connected to the main supply plenum. Therefore, it is necessary to have a clear path from the fan coil unit to the main supply plenum.

supply duct connections

There are numerous fittings required at this stage of the installation. These fittings may include couplings, block ends, reducers, elbows (90° and 45°), and tee's.

Place the fittings inside the pipe you intend to connect. After pushing the supply duct over the fitting as tight as possible, use four screws on each side of the connector to fasten. Locate the screws at 90° to one another. After securing the connector with the screws, be sure to **tape or seal all joints** to eliminate any air leaks.

elbow and tee placement

It is recommended to avoid penetrations within the first 18" of the plenum. Where possible allow 18" before installing any tee or saddle. An elbow or an offset elbow can be

incorporated in the 18" dimension. For best performance of the system, keep the number of elbows and tees to a minimum. When using elbows always use adjustable type elbows for **MaxAir(e)**TM systems. When utilizing tees that deflect both air streams at 90° angles try to maintain a 50/50 split on the air stream. When using tees that deflect one air stream at 90° try to maintain a 70% straight through to 30% at right angle ratio. These are approximate ratios plus/minus 10%.

connecting the ducts to the fan coils

Once the main plenum duct and the fan coil is in place, they can be fitted together. You may need to rotate the plenum in order to ensure your branch take-off lines up properly.

Connecting the main supply plenum with the use of flexible duct as a connector or a canvas connector is permitted. The flexible duct should be used as a connector only. The use of flexible duct as a supply plenum is not permitted.

When ductwork is being mounted in the basement between the joists, the use of appropriate sheet metal strapping (field supplied) can be used to secure the duct to the joists. When installing ductwork in the attic, it should be laid upon ceiling joists and wrapped with insulation as per local building codes. Running the duct high in the attic increases the duct losses or gains.

branch ductwork

After the floor and ceiling holes have all been located and drilled, it is time to install all the 2½" diameter branch duct. Run the 2½" branch duct parallel to the joists whenever possible. The 2½" branch duct can then be fastened to the joist with the use of strapping material. If the 2½" branch duct is installed in an unconditioned space, it must be insulated to local code and all connections must be sealed and taped to ensure a continuous vapor seal. Do not to tear or damage the

vapor barrier on the 2½" branch duct. Should it be damaged during installation the damaged portion of the branch duct/insulation must be taped (foil tape).

The minimum length of 2½" branch duct is 5', and the maximum is 15'. Should a run be shorter than the minimum flex length, the 2½" branch duct can be coiled within the cavity. The minimum bend inside diameter radius is 4". When installing the branch duct with a minimum radius ensure the duct is extended fully to allow full airflow through the elbow outlet.

Do not abuse the 2½" flex as the helix will crush and unravel.

When connecting the 2½" branch duct to the 2½" saddle, the saddle fitting needs to be inserted into the 2½" branch duct and secured with two evenly spaced TEK screws. Ensure the head of the TEK screw is seated on the wire helix as the branch duct will tear. Pull the insulation over the inner core and secure around the outside with foil tape and/or a zip tie.

When installing the 2½" branch duct in areas in which your run counters the direction of solid joists, you may need to cut a hole in the joist large enough to accommodate the branch duct providing the local building code permits.

Should this practice not be at all possible then the branch duct needs to be run below the joist.

Should you find the need to extend a branch duct from the factory supplied 10' to 15' it will be necessary to join the 2 pieces of branch duct. In order to join the two branches, a 3" piece of field supplied 2" ABS, PVC or coiled metal as a coupling needs to be inserted between the branch ducts. Use two evenly spaced TEK screws to secure the coupling on either side of the joint and tape the coupling with foil tape. Pull together and overlap the insulation and vapor barrier and tape/wrap the entire joint with foil tape ensuring no air will be able to leak out.

connecting the 2½" flexible branch duct to the supply duct

The 2½" flexible branch duct is used to connect the main supply plenum to the diffuser locations. When cutting into the supply duct, locate the 2½" saddles between the joints so as not to affect the structural integrity of the supply duct. The take off must be installed with a slight upward angle in order to keep the bend in the branch duct as gentle as possible (2 o'clock & 10 o'clock positions).

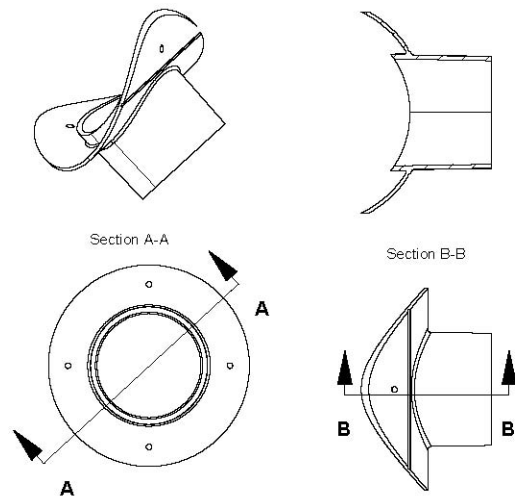

NOTE: Installations done with the main supply duct resting on trusses (e.g. In attic space) will require the take offs installed in a slight downward (4 o'clock & 8 o'clock positions). Make certain the branch duct does not create a trap.

Cut a 2¾" diameter opening in the supply duct using a hole saw, or cut by hand to suitable dimension. After all the holes have been created in the supply duct install the saddles. Place the saddles over the 2¾" holes with the gasket side toward the supply duct. Ensure that the saddle/take off rests firmly in place in the hole that you created. Firmly press the flange tight against the supply duct and screw to the surface with 4 - 3/4" self tapping sheet metal screws. It may be required to use foil tape to ensure that a better air tight seal is made.

installing the diffusers

The rough in kit is shipped in 3 pieces, the saddle/take-off, the diffuser elbow, and the dust cap. The diffuser and damper and extension are shipped separately.

branch duct termination

The branch duct vapor barrier must not be penetrated. The flexible ductwork must be installed in a gentle manner through the floor or ceiling. The maximum bend inside diameter radius of the flexible ductwork is 4".

To complete the installation, install the diffuser elbow. Ensure that the elbow is properly snapped in place and supported to accept the friction fit Diffuser & Damper. The flex duct is factory connected to the click extension, push the click extension onto the elbow until a click is heard. No additional sealant, tape or screws are necessary.

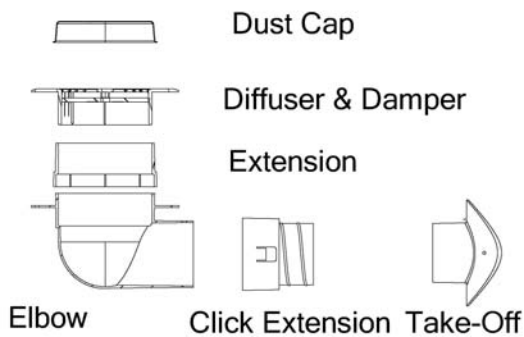

Install the branch duct as described above. Ensure the duct cap is installed to keep construction debris out of the duct.

Once the finished surface is complete remove the dust cap and install the friction fit diffuser & damper. An extension is available if the finished surface is too thick (eg. tile or hardwood flooring) to allow the diffuser to fit properly into the elbow.

If too much air is being supplied by a diffuser the diffuser balancing damper can be adjusted.

airflow

Once all the diffusers are installed, the airflow

from the vents should be checked. If you have vents that are not blowing strongly, there are a few things to check. Make sure that the 2½" branch duct is not crushed, crimped, kinked, or torn. Check for air leaks in the ducts, and seal all leaks with tape or duct sealant, as per local codes. If some vents are still not blowing strongly find the source of the obstruction.

return air duct

The return air duct is not supplied as part of the **MaxAir(e)**TM fan coil package. It is to be supplied and installed by the installing contractor. The return air and fresh air make-up ducts are to be installed as per local building code specifications and good design practices. The first five feet of the return air duct from the air handling unit is recommended to be acoustically lined for sound absorption, when the duct directly communicates with the living space.

condensation

On units supplied with an Airmax Accessory slab external cooling coil, a drain connection is provided on the cooling coil. A drain line, with a trap must be installed (*the size of the trap is discussed in the previous section*). For cooling installations where the fan coil unit is installed in hot, humid areas, condensate may form on the outer cabinet of the unit. When this potential exists, a secondary drain pan should be installed under the entire unit. This pan should also extend under the piping connections and TX valve. This is especially critical in attic installations where condensate can cause damage to the ceiling

DX refrigerant cooling

When installing the fan coil, either in the horizontal or vertical position, make certain that the unit is installed level in order to handle condensate drainage. The condensate drain should be trapped, and the

drain line sloped toward the drain at a 1/4" per foot slope. Ensure that no screws puncture the drain pan.

The Airmax Accessory slab coil must be installed in a vertical position (horizontal airflow through the coil) or condensate drainage problems will result. It is acceptable use a field supplied "A" type evaporative coil as long as the coil is located in the return air section of the system. Contact your Airmax representative for additional information.

Some building codes call for a secondary drain pan under the entire unit. Check local codes for more information. Any installation that has the potential of property damage due to condensate should have a secondary drain pan installed. If the unit is installed in a high heat and/or humidity location, extra insulation around the unit casing may be required to prevent excessive condensate from forming on the outer surface of the casing. Install the unit so that there is adequate clearance on all sides for service and for piping runs.

When connecting the refrigerant lines to the cooling coil, installations instructions with the coil should be followed. It is also recommended, but not mandatory that you install a sight glass and filter/drier at the condensing unit, as well as both high and low side access ports. This is useful for both the system setup, and for future trouble shooting.

Care must be taken when mounting the Airmax Accessory slab coil directly to the side of a Airmax vertical airflow fan coil. This is

acceptable only on the side of the fan coil opposite the fan motor end. If mounting the coil on the side where the end of the fan motor is located use a short spacer fitting to move the coil face away from the back of the motor housing. Failure to do so will cause excessive or non-uniform velocity across the coil surface and may cause condensate carry over into the fan coil cabinet.

condensing unit

Locate the outdoor unit in a suitable location, as close as possible to the fan coil. Maintain the clearances recommended by the condensing unit manufacturer's installation manual to ensure proper airflow. The outdoor unit must be installed in a level, properly supported location

anti-ice and TX valve

MaxAir™ accessory DX evaporator coils come with an anti-ice control frost thermostat (see appropriate wiring diagram) installed on the suction line. Ensure that the TXV bulb and the frost thermostat control are fastened securely and are well insulated. **DO NOT** use a self-tightening clamp on the frost thermostat as excessive tightening may damage the thermostat.

The remote sensing bulb for the TX valve should be located on a clean, **horizontal** section of the suction line. It should be mounted on the top half of the pipe in the 2 o'clock or 10 o'clock position.

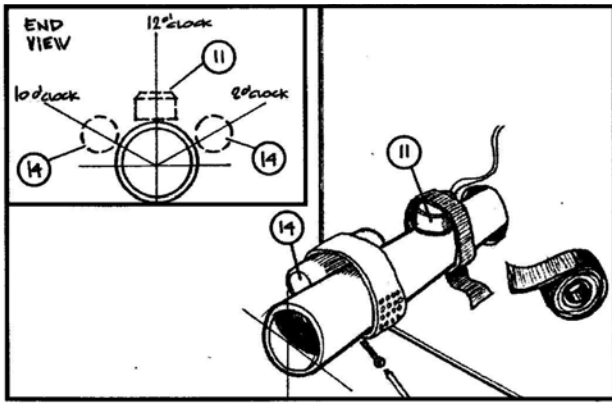

evaporator coil assembly

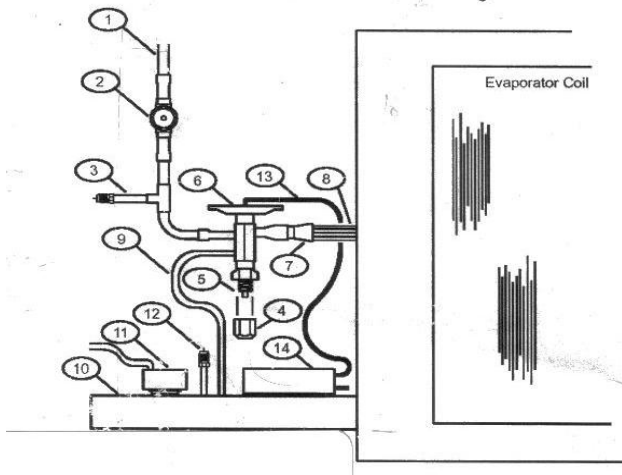

- 1) Liquid line
- 2) Site glass (not Supplied)
- 3) High side access port
- 4) Adjustment stem cap (not applicable)
- 5) Superheat adjustment stem (not applicable)
- 6) Thermal expansion valve(TXV)
- 7) Refrigerant distributor
- 8) Distributor tubes
- 9) External equalizer line
- 10) Suction line
- 11) Anti-ice control (Frost thermostat)
- 12) Low side access port
- 13) TX capillary tube
- 14) TX sensing bulb

refrigeration piping

Use only refrigerant grade pipe and fittings. Plumbing fittings may contain wax or other contaminants which are detrimental to the

proper operation of the system. Insulate the suction line as per condenser manufacturer's instructions

Install the refrigeration lines as per local codes and good piping practices, supporting the pipe every 5 feet. Run the pipes in the most direct route possible, taking into account structural integrity and building finishing details. If the evaporator is located above the condenser, slope any horizontal runs toward the condenser and provide a trap at the evaporator to prevent liquid migration during the off cycle. If the condenser is located above the evaporator, a trap must be installed in the suction line at the bottom of the vertical riser. For long vertical risers, additional traps must be installed for every twenty feet. For lines running over 50', a suction line accumulator must be installed. Lines running over 100' are not recommended.

Flow nitrogen at a low pressure through the piping when welding to prevent oxidation.

condensing unit wiring

Make all connections to the outdoor unit with liquid tight conduit and fittings. Most building codes require a rain tight disconnect switch at the outdoor unit as well. Run the proper size wire to the unit, and connect as per the manufacturer's recommendations. Ensure that the unit is setup for a TX valve system. If not, a hard start kit may be required.

evacuating and charging

After the piping is installed, and all components connected, pressurize the system and check for leaks. The use of an electronic leak detector is recommended, as it is more sensitive to small leaks under the low pressures commonly used for initial leak detection.

Fill the system with nitrogen to 100 psig and test for leaks. Using a good, quality vacuum pump, evacuate the system from both the low and high side of the system to 500 microns

and ensure that the system holds at the vacuum pressure. If not, check for leaks and evacuate again. If the vacuum is maintained, add refrigerant to raise the pressure to 2 psig,

and either open the service valves (suction first) on pre-charged condensing units, or add refrigerant to the system until the proper operating charge is obtained.

ELECTRICAL

The DCC7235 is a microcontroller-based electronic volume controller for brushless dc motor-driven fan coils, furnaces or other systems. It commands discrete or variable blower speeds, torques or airflow in heating, cooling and ventilation modes from inputs provided from a discrete or proportional thermostat or controller whose switched 24VAC signal outputs activate a blower's air volume. Discrete output blower command values are selected and scaled from tables, individually selected by dip-switches. One controller can be used with several different products of different capacities. An on-board dip-switch optionally selects a 0-10V input for variable/proportional volume control. The DCC7235 can be used with proportional, 1-stage HEAT/COOL, 1 or 2-Stage COOL, and 1 or 2-Stage HEAT thermostats.

Five relay contact outputs are available for activating accessories. Two are high voltage, dry contacts. Three others switch the 24VAC ("R") powering the controller. One of those three can be isolated from "R" by removing a shunt and providing 24VAC dry contacts.

1. DCC7235 LAYOUT

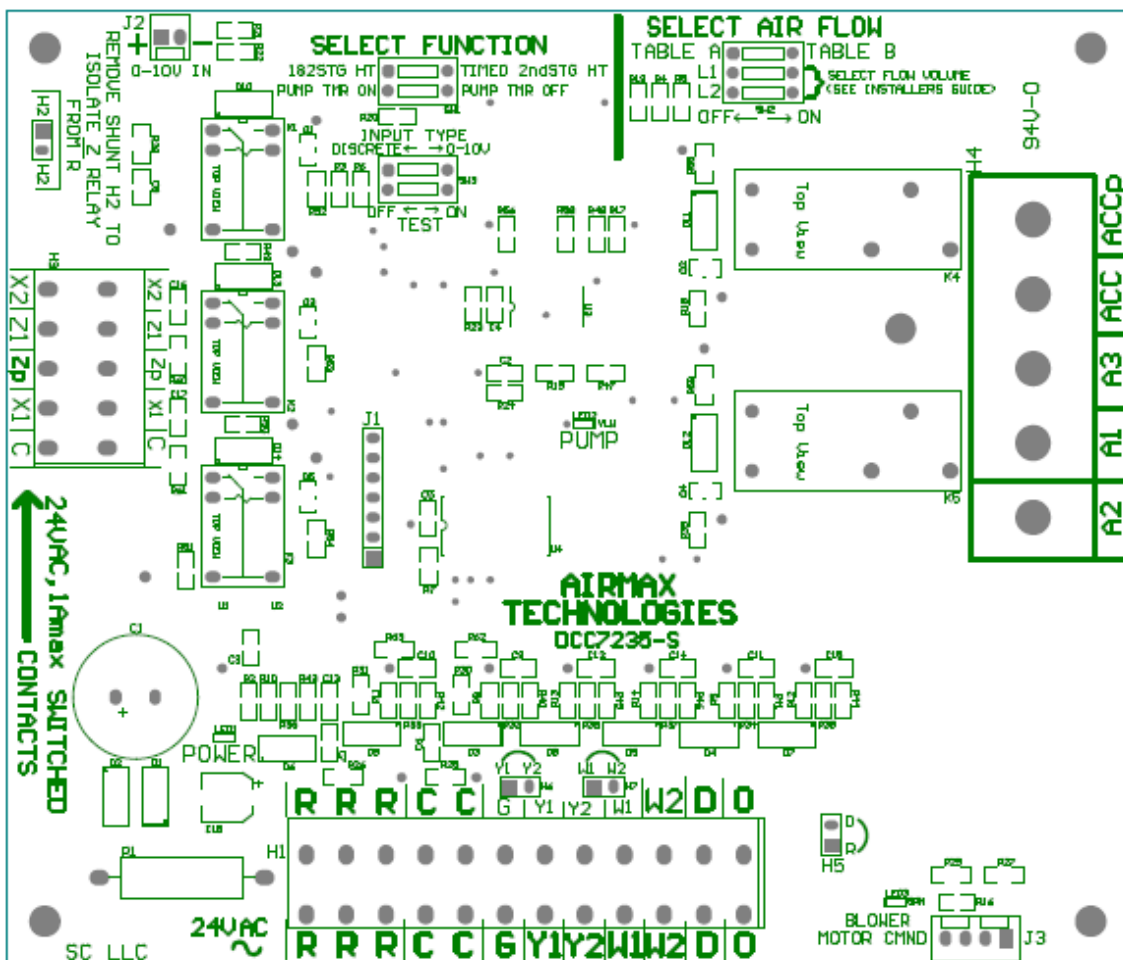

FIG 1

2. POWER:

24VAC (nominal) supplied by a Class II transformer between terminals "R" ("24VAC LINE") and "C"

("24VAC RET"). The **RED "POWER" LED** illuminates when the control is powered.
 Transformer rating: 20VA minimum
 Voltage: 22.5Vac Minimum, 30Vac Maximum
 Current: <100ma (All outputs and relays active)

NOTE: SUPPLY 24VAC POWER FROM THE SECONDARY OF AN NEC CLASS-2 TRANSFORMER ONLY.

3. CONTROL SYSTEM INPUTS

a.) **0-10vdc Command** — When SW3-1 "TEST" is **ON**, a 0-10 VDC input to J2 between Vin+ and Vin- produces a variable PWM output of 0% through 100%. **The polarity of the input signal must be observed.** See Figs 1 & 2:

Differential Input Voltage: 0 V to 10 VDC represents 0 to 100% PWM
 Maximum Input V dc: +10.2 Vdc
 Common Mode Voltage: - 0.2 V max negative, +5 V max positive
 Signal (differential) Input impedance: >150K Ohm (Vin+ to Vin-)
 Common mode impedance: > 150K Ohm to COM

ON/OFF: ON = input VDC > 0.5VDC +/- 0.1V
 OFF = input VDC <0.4VDC +/- 0.1V

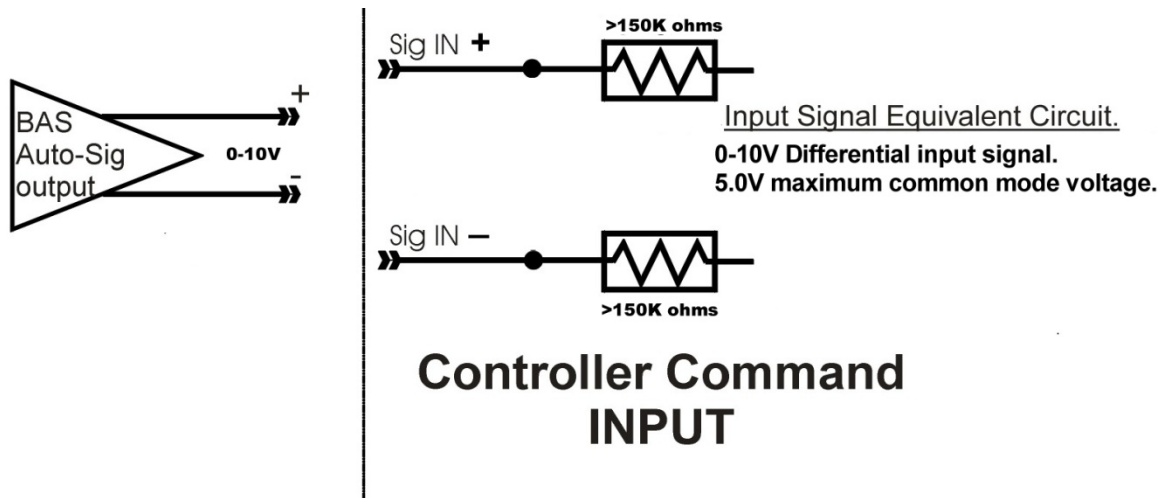

FIG 2

b.) **Switched 24VAC INPUTS (SW3-1 IN "DISCRETE POSITION": (see para. 5.)**

- G — Fan Only MODE
- Y2 & O & G — HIGH COOL MODE
- Y1 & O & G — LOW COOL MODE
- W1 — 1st STAGE HEAT MODE
- W2 — 2nd STAGE HEAT MODE
- Y1 & G & NOT O — Low Stage Heating (with Heat Pump)
- Y2 & G & NOT O — High Stage Heating (with Heat Pump)
- D — Accessory Control (Dehumidifier, Aquastat, etc). D is connected to "R" when shunt **H5** is in place. Remove H5 to control the D terminal by an external switch.

b.1.) INPUTS SPECIFICATIONS

Input Impedance:

Y1 and Y2

~1K Ohm between: each terminal to **C** (24VAC Return).

Minimum acceptable cooling anticipator resistance: 3.3K Ohms between 24Vac(R) to Y1 or Y2

All other inputs:

>10K Ohm between each terminal and **C** (24VAC return).

Load Current FORM FACTOR — All Inputs: Positive Half-Wave (with respect to **C** (24VAC RTN)

MIN AND MAX INPUT VOLTAGE – All 24VAC Inputs:

Signals ACTIVE: 20VAC minimum. 30VAC Maximum; Current: <15ma @30VAC.

Signals INACTIVE: <4VAC (Current from any signal source, switch, and/or external snubbers must hold inputs to <4VAC or DC)

NOTE: DO NOT CONNECT THE SWITCHED 24VAC INPUTS FROM A 2nd, SEPARATE TRANSFORMER THAN THE 24VAC SOURCE SUPPLYING POWER TO THIS CONTROL UNLESS THE TRANSFORMER SUPPLYING THIS CONTROL AND THE 2ND TRANSFORMER ARE PHASED PROPERLY WITH THEIR COMMONS CONNECTED.

4. OUTPUTS

A. CONNECTIONS TO EC MOTOR (ECM): J3 PIN-OUTS (SEE FIG 3):

J5-pin-1: **START/STOP:** When the Blower motor is commanded to operate this signal enables motor operation. (Use is optional. Use if the system requires a separate enable.)

0VDC = not enabled, 22VDC (nom) = enabled

10ma maximum sourced current.

J5-pin-2: **COMMON** – J5 Outputs Common (to **isolated** common input(s) on motor/drive).

DO NOT CONNECT COMMON TO 24VAC RET

J5-pin-3: **PWM Motor Command:** 0% to 100% duty-cycle.

OFF: 0VDC (min). ON: 22VDC (peak). 10ma max sourced current.

When measured on a DC voltmeter, the signal level varies from 0VDC to ~22VDC max as the percent PWM duty cycle increases from 0 to 100%.

The **Green LED “BLWR CMND”** illuminates when the PWM command is active.

Brightness increases with PWM duty cycle.

J5-pin-4: NO CONNECTION

B. HIGH VOLTAGE RELAY OUTPUTS:

a. A1, A2, A3 (PUMP) Relay (Formerly “WV RELAY”)

Contacts A1 (NO), A2 (NC) to A3 (Pole): A3 is “Dry” and can be connected to an external voltage source for switching to A1, A2.

The WV Relay is energized under the following conditions:

1) SWITCH “PUMP TMR ON” POSITION, **AND**

2) Upon detecting a call for W1 or W2 (no delay) **OR**

3) If W1 or W2 was not active for 6 (or 24) consecutive powered hours.

The **green “W_TIMER” LED** illuminates when the PUMP relay is activated.

b. ACCESSORY Relay (ACC, ACCp):

Contact ACC (NO) connects to pole ACCp. These are DRY Contacts and can be connected to an external voltage source.

The Accessory relay is energized with “**G**”. i.e. Any call from the thermostat **that includes** an active “G” signal energizes this relay.

c. MAXIMUM CONTACT

RATINGS:

8A @120 VAC (resistive)
8A @ 240 VAC (resistive)

C. LOW VOLTAGES RELAY OUTPUTS:

All Three low voltage relay contacts are rated 1AMP maximum @ 30VAC maximum.

a. "X1" LOW STAGE "Y" RELAY (Contact X1):

- i. The LOW Stage Y relay activates upon detecting a call for "Y1" (with or without "O" active).
- ii. Upon activation, the X1 terminal connects to "R" (the 24VAC powering the DCC7235). **This relay is NOT DRY; i.e. its pole is permanently connected to "R".**

b. "X2" High Stage "Y" RELAY" (Contact X2):

- i. The HIGH Stage Y relay activates on a call for Y2 (with or without "O" active).
- ii. On activation, the X2 terminal connects to "R" (the 24VAC powering the DCC7235). **This relay is NOT DRY; i.e. its pole is permanently connected to "R".**

c. "Z" RELAY" (Contacts Z1, Z1p):

- i. The Z1 terminal switches to Zp on any "W" call (W1 or W2).
- ii. **As shipped, SHUNT H2 connects Zp to "R", i.e. THE W RELAY CONTACTS ARE NOT "DRY" AS SHIPPED.** See diagram below.
- iii. **WHEN H2 is removed** the contacts are "DRY" and be connected to a second, separate, isolated 24VAC power source. See diagram below.

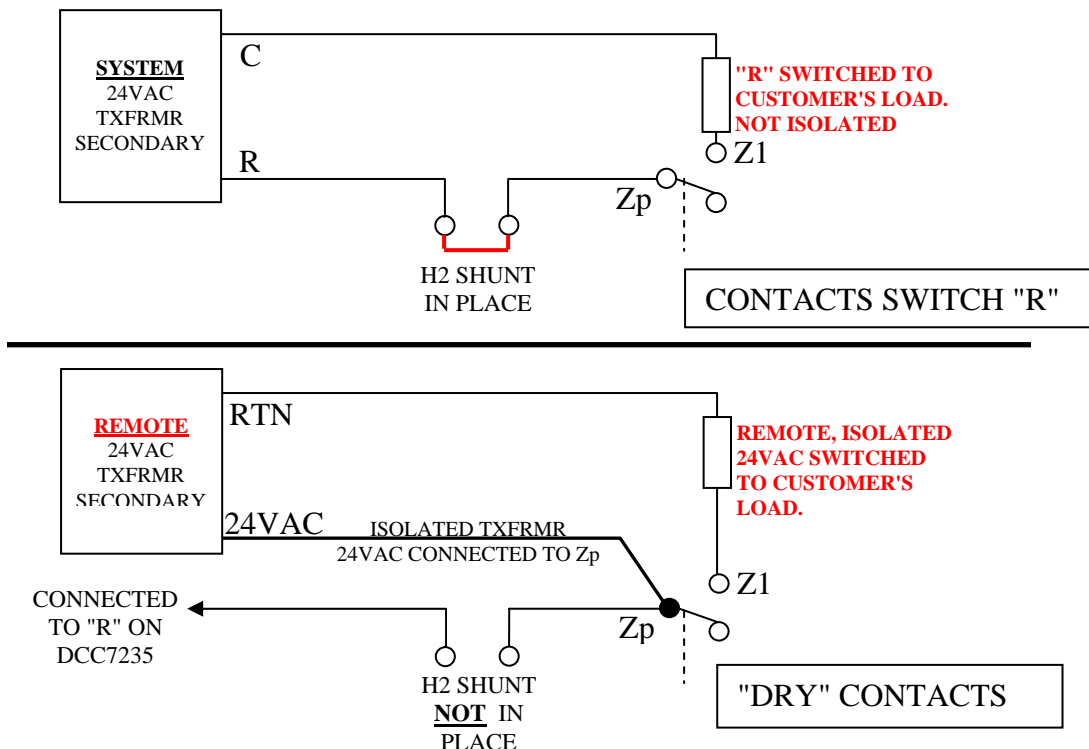

a. **DISCRETE/VARIABLE (0-10V) MODE INPUT SELECTOR (SW3-1)**

1. **SW3-1 IN "DISCRETE" SWITCH POSITION: TABLE A-B PWM OUTPUT SIGNAL LEVEL SELECTOR:**

The switch labeled "TABLE A", "TABLE B" in combination with the switches labeled "L1" and "L2" select the flow levels for each of the discrete input states. Each Discrete input or combination of inputs activates a pre-programmed selection of customer-specified PWM duty-cycle output. The various combinations are used to operate equipment with different capacities. The selections are per in the tables below:

TABLE A (SW2-1) SWITCH "OFF" POSITION:





SET MAX AIRFLOW SEL 1&2	"L1,L2" SELECTIONS WITH DISCRETE INPUT TABLE A SELECTED							
	G(ONLY)	Y2 & G & /O	Y1 & G & /O	Y2 & G & O	Y1 & G & O	W1 & D	W2 & D	(W1 or W2) & /D
L1, L2=0 	20%	100%	60%	100%	60%	50%	100%	20%
L1=1,L2=0 	20%	100%	60%	100%	60%	35%	83%	20%
L1=0,L2=1 	20%	83%	50%	83%	50%	35%	83%	20%
L1,L2=1 	20%	83%	50%	83%	50%	25%	50%	20%

TABLE B (SW2-1) SWITCH "ON" POSITION:

SET MAX AIRFLOW (Dip-SW2)	"L1,L2" SELECTIONS WITH DISCRETE INPUT TABLE B SELECTED							
	G(ONLY)	Y2 & G & /O	Y1 & G & /O	Y2 & G & O	Y1 & G & O	W1 & D	W2 & D	(W1 or W2) & /D
L1, L2=0 	20%	66%	35%	66%	35%	35%	66%	20%
L1=1,L2=0 	20%	50%	25%	50%	25%	25%	50%	20%
L1=0,L2=1 	20%	35%	20%	35%	20%	20%	35%	20%
L1=1,L2=0 	20%	25%	20%	25%	20%	20%	25%	20%

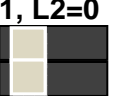
NOTE: TABLE A OR B AND SELECTIONS WITHIN TABLES A AND B BECOME EFFECTIVE WITHOUT CYCLING 24VAC POWER 2 TO 4 SECONDS AFTER CHANGING SWITCH POSITIONS.

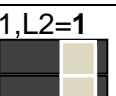
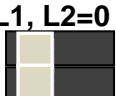
2. **SW3-1 IN "0-10V IN" SWITCH POSITION:** Selects **CONTINUOUSLY VARIABLE**

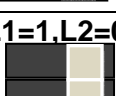
outputs per table 3, below and the command (volume) level is input via the "0-10V IN" connector:





L1,L2 SELECTIONS WHEN 0-10V INPUT ACTIVE		
SET MAX AIRFLOW (DIP-SW2)	COMMAND INPUT RANGE	COMMAND OUTPUT RANGE
L1,L2=0 	0-10V	0-100%
L1=1,L2=0 	0-10V	0-83%
L1=0,L2=1 	0-10V	0-66%
L1,L2=1 	0-10V	0-50%

TABLE3

NOTE: POWER TO THE CONTROLLER MUST BE CYCLED FOR THE DISCRETE OR 0-10V SWITCH STATE TO BE RECOGNIZED. THE SELECTED STATE BECOMES EFFECTIVE AFTER POWER IS RESTORED.

B. ONE AND TWO STAGE HEATING SYSTEM SELECTOR

1. **"1&2-STG HT" (SW1-1):** In this position, single-stage and true two-stage heat control from a thermostat is operational. The Heating inputs (W1, W2) will operate the system as follows:

1. **OPERATING With a FURNACE ("Y" not Active in Heating)**

D & W1 active: When "1&2-Stg HT" and D AND W1 are active, the selected output PWM % shown under W1 in TABLES A and B, above, occurs after a 15 sec delay after any W activates.

D & W2 active: When "1&2-Stg HT" AND D AND W2 are active, the selected output PWM % shown under W2 in TABLES A and B occurs after a 15 sec time delay after W1 or W2 activate.

W2 has precedence over W1: If either W1 and W2, or W2 alone, is active, the W2 command output occurs.

STAGING DELAY: There is no time delay when sequentially staging from W1 to W2 or back (i.e. without an OFF-CYCLE).

For convenience, when a single stage HEAT system is applied, an on-board SHUNT connects W1 to W2 for operation at the W2 airflow whenever any W is active.

NOTE: THE SHUNT MUST BE REMOVED WHEN A TWO STAGE HEATING SYSTEM IS APPLIED.

active, the output will be per the column (W1 or W2) & NOT D in Tables A and B.

2-stage WIRING: True 2-stage (2-wire: W1, W2) operation requires the W1 and W2 terminals of the thermostat to be wired to W1 and W2, respectively, on the DCC7235.

1-stage Wiring: Single stage operation can still be achieved by wiring only W1 from the thermostat to W1 of the DCC7235 for **LOW** airflow, or W2 from the thermostat to W2 of the DCC7235 for **HIGH** airflow. W1 and W2 can also be connected (jumpered) for HIGH Airflow in 1-stage systems.

For convenience, when a single stage system is applied, an on-board SHUNT connects Y1 to Y2 for operation at the Y2 airflow whenever any Y is active.

NOTE: THE SHUNT MUST BE REMOVED WHEN A TWO STAGE COMPRESSOR SYSTEM IS APPLIED FOR HEATING OR COOLING.

2. **OPERATING with a HEAT PUMP ("Y" MUST BE Active for COMPRESSOR Heating)**

D & W1 active: When "1&2-Stg HT" and **D AND W1** are active, the selected output PWM % shown under **W1** in the selected TABLE A and B, above, occurs after a 15 sec delay after any **W** first becomes active. A prior flow value (PWM%) selected by either **Y** will be replaced by the value selected by either **W**.

D & W2 active: When "1&2-Stg HT" and **D AND W2** are active, the selected output PWM % shown under **W2** in the selected TABLE A and B occurs after a 15 sec time delay after the first occurrence of **W1** or **W2**. A prior flow value (PWM%) selected by either **Y** will be replaced by the value selected by either **W**.

NOTE: WHEN EITHER OR BOTH W1 AND W2 ARE ACTIVE AND D IS NOT ACTIVE, THE OUTPUT WILL BE PER THE COLUMN (W1 OR W2) & NOT D IN TABLES A AND B.

2. **"TIMED 2-STAGE HEAT" SWITCH (SW1-1) "ON"**

1st stage -- D & W1 or D & W2 active: When the switch is in this position and either **W1 & D** or **W2 & D** are active, the volume command (PWM %) shown under **D & W1** in the selected TABLE A or B occurs after a 15 sec time delay from when W1 or W2 became active.

TIMED STAGING: When either **D & W1** or **D & W2** remain active for 5 minutes, the volume command (PWM %) transitions to the selected values shown under **D & W2** in the selected TABLE A or B, above, to give the high volume output.

When W1 or W2 is active and D is NOT active, the Output will be per the column (**W1 or W2**) & NOT D in Tables A and B.

TIMED STAGING WIRING: Either an energized W1 or W2 alone, or W1 and W2 together (for example, by connecting them together with an external shunt) will activate the timed 2-stage output.

NOTE: POWER TO THE CONTROLLER MUST BE CYCLED FOR THE 1&2-STG HT AND TIMED 2-STG HT SWITCH STATE TO BE RECOGNIZED. THE SELECTED STATE WILL BECOME EFFECTIVE AFTER POWER IS RESTORED.

C. **PUMP TIMER RELAY ON-OFF (ENABLE/DISABLE)**

- a. **"PUMP TMR ON":** The Pump RELAY Timer functions normally and will activate per paragraph B. a., above.

b. "PUMP TMR OFF": The Pump RELAY Timer is disabled and will not activate.

D. NORMAL & TEST MODE TIMING (SW3-2 "TEST"):

NOTE: THIS SWITCH SELECTS NORMAL OPERATION OR THE TEST MODE

PUMP SWITCH (A1, A2, A3) TIMING AND FUNCTION LOCKOUT.

THE FOLLOWING DIAGRAM SHOWS THE TIMING OF THE PUMP RELAY. ITS OPERATES WITH THE TIMING AND BLOWER AND X1,X2 RELAY LOCKOUT PERIODS SHOWN.

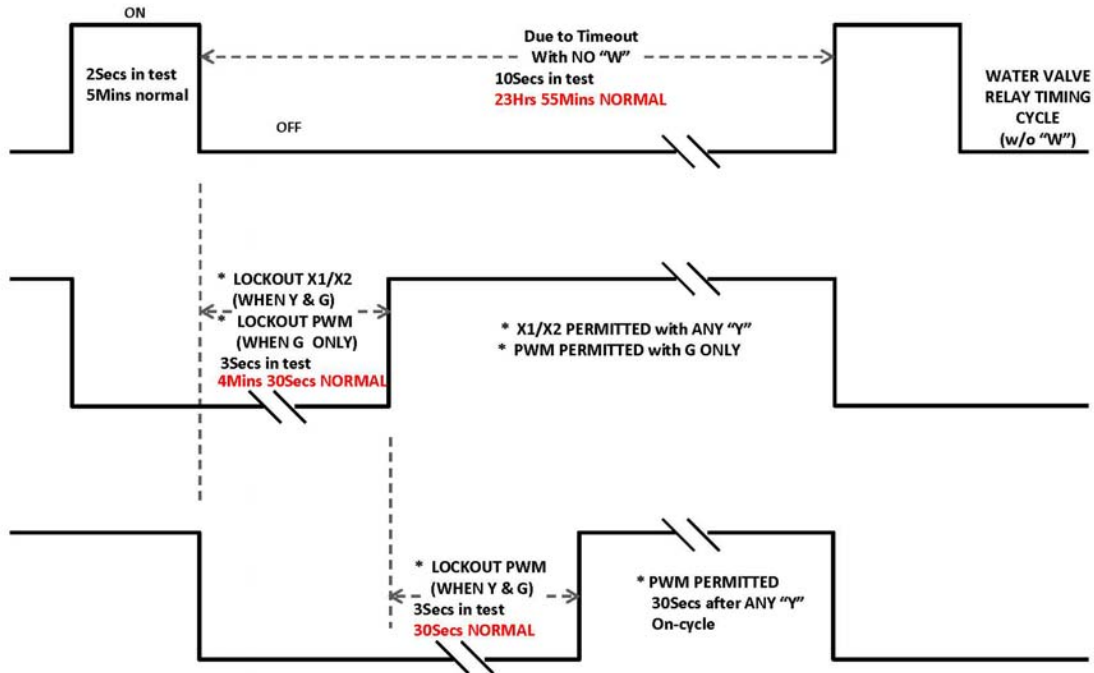

NOTE: POWER MUST BE CYCLED TO ENTER OR TO LEAVE THE TEST MODE. THE SELECTED STATE (TEST OR NORMAL OPERATION) BECOMES EFFECTIVE ONLY AFTER POWER IS RESTORED.

TYPICAL HOOKUP

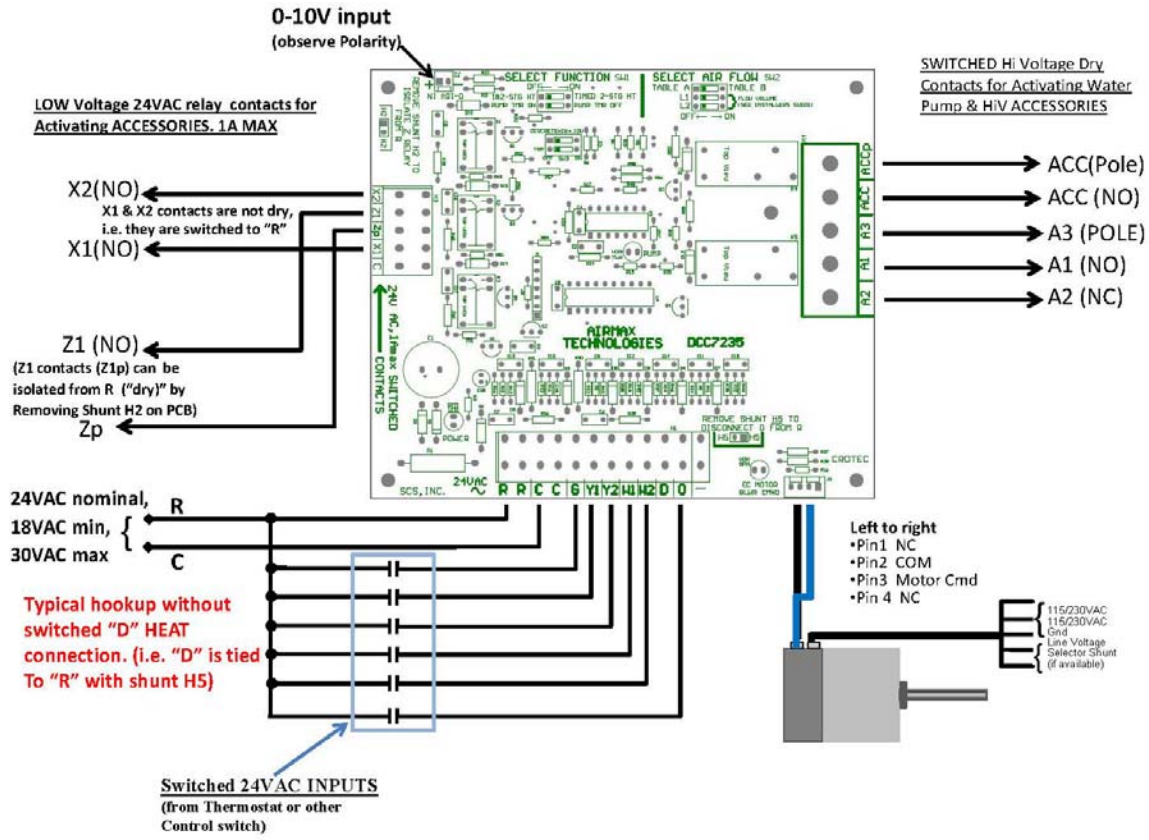

Confidential & Proprietary Information

FIG 3

6. DIMENSIONS and MOUNTING:

PC Board Dimensions: 4.8" x 5.66"

Mounting: 5 Nylon standoff snap-in feet

Hole centers: 4 at: corners spaced 4.5" x 5.26"

1 at: down 1.40", and in-board (left) 0.960" from center of top right corner standoff.

Recommended hole size: 0.191"

START-UP PROCEDURES

Do not start the air handler or water heater until ALL air has been purged!

parts of the plumbing system.

1. Fill the water heater or boiler, and or storage tank with water.
2. Purge all air for the domestic water lines by opening faucets at the remote

3. Purge all air from the space heating loop by closing the isolation valve on the return leg of the loop and open the drain to purge air. Open the return leg isolation valve and then close the drain valve. If no isolation valves are installed, open drain fully to purge air and let run for at least 30 seconds.
4. Start the water heater or boiler according to the manufacturer's instructions. Set the desired water temperature (140F/60C) and wait for the tank to shut off.
5. Turn on the power to the air handler and set the room thermostat for heat to energize the fan and pump. If a gurgling sound is present, it should subside within one minute. If noise is still present after one minute, repeat step 3 to purge air as necessary.
6. Grab hold of the heating lines with your hands to verify that they are getting warmer due to the hot water circulating through them. Also verify the circulating pump is operating by feeling for the vibrations. With the air handler running, ensure water flow through the circulation loop by measuring the water temperature difference. It should be in the range of 10-30°F temperature drop through the air handler with an entering water temperature between 135-180°F.

HINT: The temperature drop across the air handler can easily be measured with a probe type pocket thermometer. Wrap a rag or piece of insulation around the inlet and outlet of the heating coil to the air handler and insert the thermometer probe between the insulation and the pipe to take the reading. Wait at approximately 2 minutes to take each reading (*longer for systems with a storage*

tank). Make certain to take both readings one immediately after the other. At high flow rates the temperature in the tank may drift, causing error in the calculated temperature difference, if readings are taken more than 4 minutes apart.

Ensure that all electrical connections are tight, and that any packing or shipping restraints are removed from both the fan coil, and the condensing unit. With the power to the condensing unit off, check the thermostat for normal operation, and again check that there is proper airflow from all the vents. Ensure that no branch ducts were damaged or bent sharply. Do not run the fan coil without a filter in place.

DO NOT LEAVE THE SYSTEM UNATTENDED UNTIL NORMAL OPERATING CONDITIONS ARE OBTAINED.

Observe the condenser pressures during the initial start-up of the system. Check the voltage and amp draw of both the fan coil, and the outdoor condensing unit. The voltages must be within 10% of the rating plate data. If more than a 10% difference is noted, contact your local electrical company. Check that the amprage draws on both the air handler and condensing units are within the information printed on the unit rating plates. Set the refrigerant charge as required for optimal performance.

DO NOT USE THE FAN COIL FOR TEMPORARY HEAT DURING CONSTRUCTION. THIS WILL VOID ALL UNIT WARRANTIES

UNDERSTANDING THE ZONE CONTROLS

The zoning controller serves as the brains of the zoning system. The zone controllers have a built-in computer to monitor the thermostats

and the HVAC equipment, and to open and close the dampers.

- The zone panel has a connection to hook up thermostats.
- The zone panel has a connection to the fan coil main control board.
- The zone panel has a connection to power the zone dampers.
- The zone panel has a connection for 24-volt power.
- The 3-zone panel has a connection to the air plenum to monitor the air supply temperature.

When the zone panel is running, here is what happens:

At rest, when no zones are calling for heating or cooling, all dampers are open and the fan is off.

As soon as a thermostat calls for a temperature change in one or more of the zones, the zone panel reacts by making several changes. First, all dampers other than the calling zone(s) close to the minimum position. Then, the heating or cooling equipment is turned on along with the corresponding fan control. The system continues in this state until one of two things happen:

The first case occurs when the zone is satisfied. The equipment is turned off, along with the fan control, and all dampers return to their open state.

The second case occurs when a zone is heating or cooling and an opposite call occurs from one or more of the other thermostat zones. An opposite call is a call for heating when the system is already

cooling, or a call for cooling when the system is already heating. The opposite call can be handled one of two ways:

- **Zone 1 Priority** ensures opposite calls are only answered if they are either from zone 1, or match the last call from zone 1. This method is used when you have an area that should get the highest priority, and the kind of call from that area sets the mode (heating or cooling) for the rest of the building.

The zone panel can also be configured to handle opposite mode calls with a timer. This mode is called All Priority.

- **All Priority** allows the existing call to continue for 15 or 20 minutes, and then starts to switch over even if the first call is not done. The switchover starts with a purge, where the heating or cooling equipment is shut off, while the fan continues to run with the dampers left just like they were. With the equipment off, and the fan running, the conditioned air is “purged” from the system until the air is nearly room temperature. At that time, the zone controller switches on the equipment for the opposite mode, and opens the dampers for the opposite calling zone, and closes the original calling zone dampers. The switchover is now complete.

The system will continue in this state until either the call is satisfied, or if the opposite mode calls, in which case, the entire purge/changeover cycle will start over again. This normal operating mode for the zone panel will continue until all thermostats no longer call for heating or cooling.

USING THE ZONE CONTROL WITH MULTI-STAGE EQUIPMENT

All zone panels are designed to work with multi-stage HVAC equipment.

The 2-zone panel will work with two heating stages and one cooling stage. The 3-zone panel will work with up to three heating and two cooling stages. If multi-stage equipment is attached to the zone panel, additional features will be used to maximize occupant

comfort and economy. The 2-Zone Panel monitors the amount of time a heating call has lasted. Calls that do not last very long will make maximum use of the more economical first stage. If the call is not satisfied after 20 minutes, the zone panel automatically activates the second stage.

The 3-Zone Panel monitors time and the plenum temperature to maximize economy. The plenum temperature sensor helps the equipment stage by looking at the supply temperature and comparing it to the high or low limit. If the temperature differs by more than the fixed amount from the limit, the zone panel will permit staging. If the supply temperature approaches the limit, the panel

will shut off the second stage. If the supply temperature crosses the high or low limit, the panel turns off the equipment, and switches the fan on until the temperature comes back into limits. The 3-zone panel can also control a two speed fan. Depending on the installer preferences, the fan can switch to high speed if either two zones or two stages are calling.

UNDERSTANDING THE ZONE CONTROLLER DISPLAY

All Zone panels provide easy to read indicators to determine the state of the zone panel. By looking at the indicators, it is easy to determine the status of the dampers and equipment.

Table 4 2-Zone Panel Indicators

Function	Color	Callout	Description
Panel Heartbeat	Green	1	Flashes once per second when normal
Equipment RH Power	Red	2	Indicates power at equipment RH terminal
Equipment RC Power	Red	2	Indicates power at equipment RC terminal
Panel Power	Green	3	Indicates 24VAC available to panel
Zone 1 Damper	Dual	4	Red when closed, green when open
Zone 2 Damper	Dual	4	Red when closed, green when open

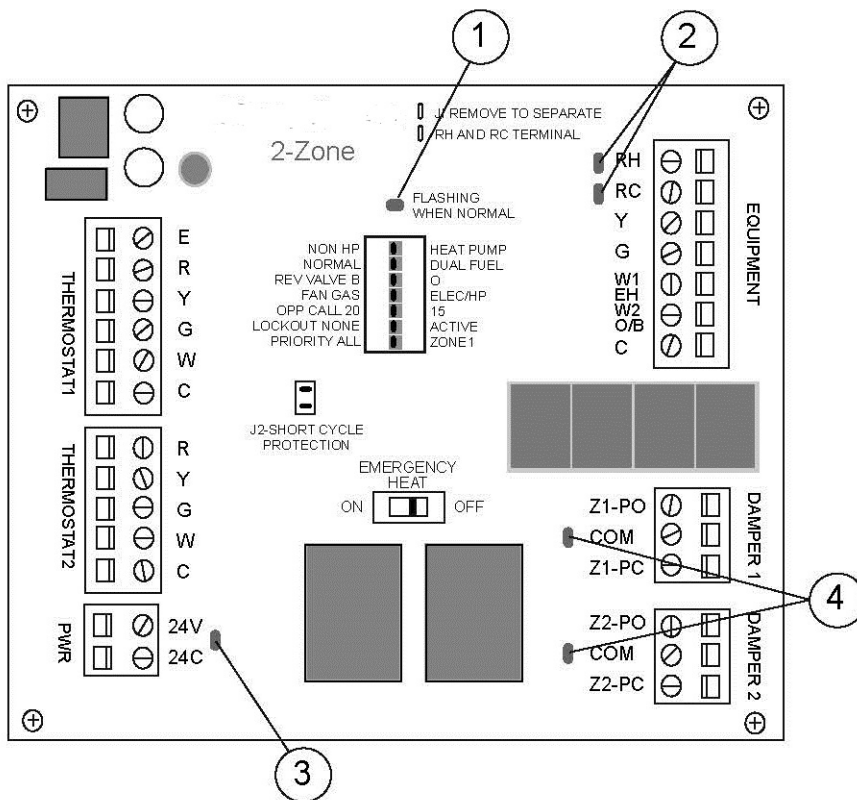
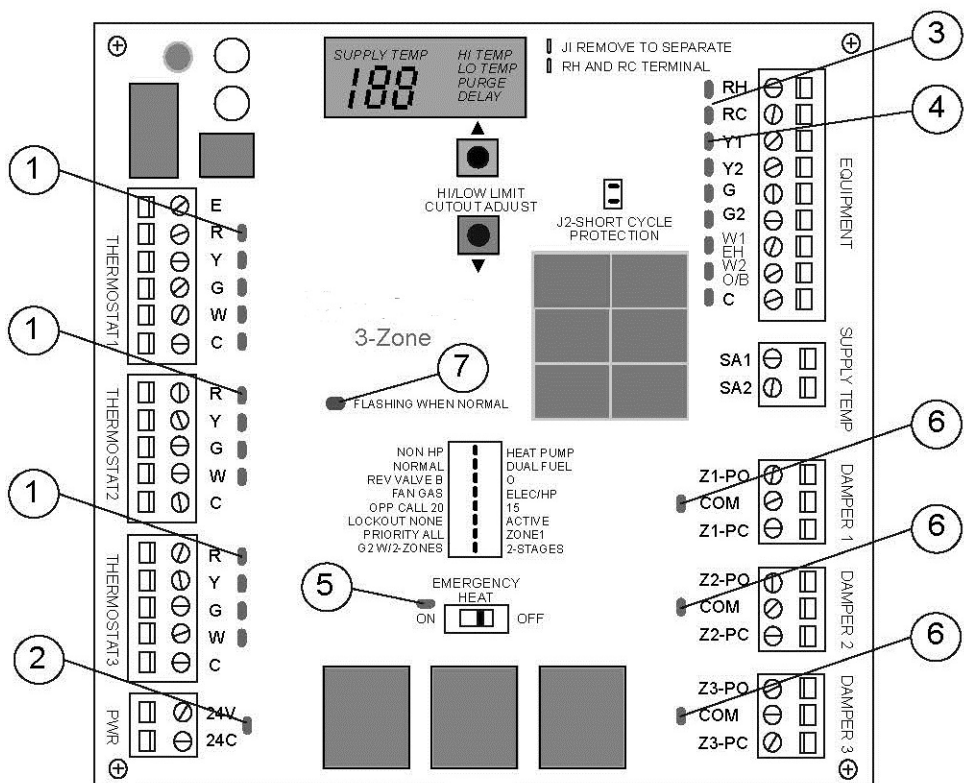

Table 5 3-Zone Panel Indicators

Function	Color	Callout	Description
Thermostat1,2 and 3R	Red	1	Zone thermostats power monitor
Thermostat1,2 and 3Y	Yellow	1	Zone thermostats compressor call
Thermostat1,2 and 3G	Green	1	Zone thermostats fan call
Thermostat1,2 and 3W	White	1	Zone thermostats heating call
Panel Power	Green	2	Indicates 24VAC available to panel
Equipment RH Power	Red	3	Indicates power at equipment RH terminal
Equipment RC Power	Red	3	Indicates power at equipment RC terminal
Equipment Y1	Yellow	4	Indicates a first stage compressor call
Equipment Y2	Yellow	4	Indicates a second stage compressor call
Equipment G1	Yellow	4	Indicates a first stage fan call
Equipment G2	Yellow	4	Indicates a second stage fan call
W1/E/W3	White	4	Heating call depending on configuration
W2/O-B	Orange	4	Heating or valve control depending on configuration
EM Heat	Yellow	5	Indicates emergency heat has been activated
Zone 1 Damper	Dual	6	Red when closed, gr
Zone 2 Damper	Dual	6	Red when closed, green when open
Zone 2 Damper	Dual	6	Red when closed, green when open
Panel Heartbeat	Green	7	Flashes once per second when normal



CONFIGURING THE ZONE PANEL

All Zone Panels feature easy to configure DIP switches that eliminate concerns about configuration loss after a power failure. The installer can also tell at a glance that the panel is set up properly prior to leaving the job site. Which is faster for the installer? Go back through 25 menu steps versus one

glance at the DIP switches to insure a panel is set up properly.

Both the 2-zone and the 3-zone panel use similar DIP switch setup, while the 3-zone has additional features for temperature control of staging.

Table 6 2-Zone Panel Configuration

Switch Number	Switch Label	Switch Function
1	Non-HP/Heat Pump	Conventional or heat pump control of W/Y
2	Normal/Dual Fuel	HP 1 st Stage lockout on 2 nd stage call
3	Rev Valve B/O	O/B terminal active in heating (B) or cooling (O)
4	Fan Gas/Elect & HP	Fan controlled by HVAC system or panel
5	Opp Call 20/15	Opposite call answer time in minutes
6	Lockout None/Active	2 nd stage lockout with 2 zones calling
7	Priority All/Zone 1	Changeover priority zone 1 or first call
J1	Separate RC RH	Remove for dual transformer installation
J2	Short Cycle Protection	When on, panel provides compressor short cycle protection. When off, HVAC equipment provides short cycle protection

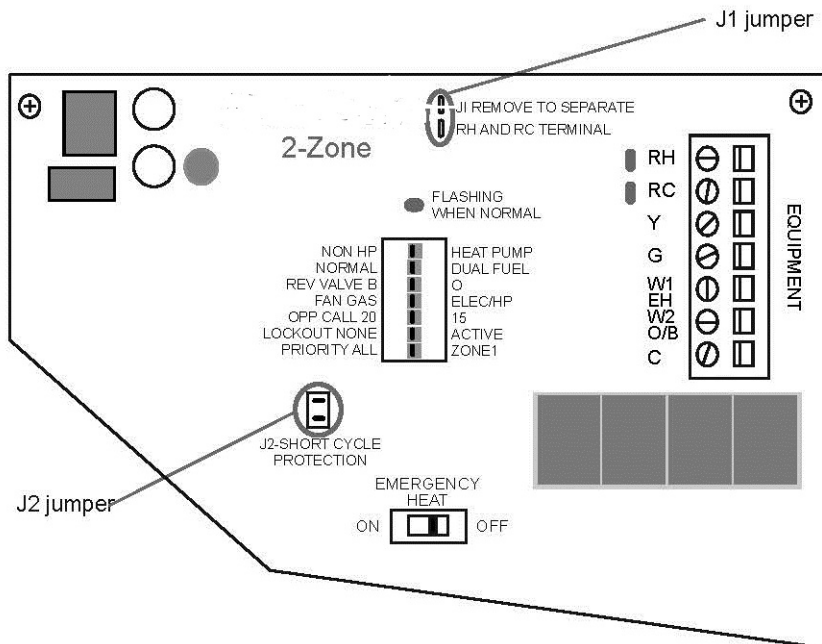
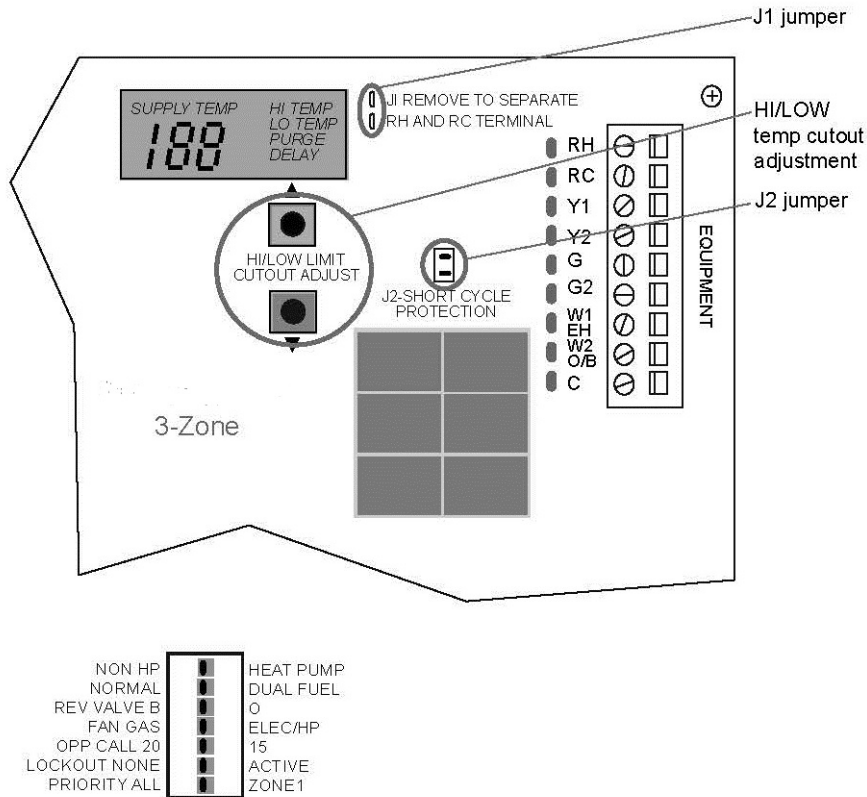

Table 7 3-Zone Panel Configuration

Switch Number	Switch Label	Switch Function
1	Non-HP/Heat Pump	Conventional or heat pump control of W/Y
2	Normal/Dual Fuel	HP 1 st Stage lockout on 2 nd stage call
3	Rev Valve B/O	O/B terminal active in heating (B) or cooling (O)
4	Fan Gas/Elect & HP	Fan controlled by HVAC system or panel
5	Opp Call 20/15	Opposite call answer time in minutes
6	Lockout None/Active	2 nd stage lockout with 2 zones calling
7	Priority All/Zone 1	Changeover priority zone 1 or first call
8	G2 W2-Zone/2 stages	High speed fan will come on when 2 zones or 2 stages call
J1	Separate RC RH	Remove for dual transformer installation
J2	Short Cycle Protection	When on, panel provides compressor short cycle protection. When off, HVAC equipment provides short cycle protection



ADDITIONAL FEATURES OF THE 3 ZONE PANEL

The 3-Zone Panel has additional features to control staging by monitoring the temperature of the HVAC plenum. By using the Hi and Lo Temp cutout switches the installer can configure the panel to operate in the most economical mode.

When the 3-zone panel is configured for a conventional system, the panel will upstage the heating equipment if the plenum temperature is 25 degrees less than the cutout. If the panel is configured for heat pump, staging occurs at 10 degrees less than

cutout. The same limits are used for cooling staging.

The limit switches are located directly below

the 3-zone panel LED. The display informs the user of the panel condition and the plenum supply temperature.

Table 8 3-Zone Panel LED

Function	Colour	Description
Purge Indicator	Yellow	Indicates user zone purge underway
Delay Indicator	Yellow	Indicates user panel is in timed wait period
Lo Temp Indicator	Red	Indicates user Lo Limit has been exceeded
Hi Temp Indicator	Red	Indicates user Hi Limit has been exceeded
Supply Temp Indicator	Red	Indicates supply plenum temperature

2 AND 3 ZONE PANEL CHECKOUT

The installer guide for both panels includes a complete checklist for the installer to use to ensure the zoning system is functioning properly. The checkout steps include:

- Apply power to the panel and ensure the panel-condition LEDs illuminate.
- Switch on zone 1 thermostat and ensure conditioned air is only moving into zone 1.
- Switch on the remaining zone thermostats

one zone at a time and ensure conditioned air is only moving into that zone.

- Test the emergency heat and air-conditioning equipment if the outside temperature permits.
- Shut off all zones and confirm purge cycle and bypass operates as expected.
- Restore thermostats to their normal operating condition.

SEQUENCE OF OPERATION P2

Refer to Ladder Diagram and Wiring Schematic for relay locations.

Note: **MaxAir™** air handlers are equipped with a brushless dc fan motor. Speeds for heating, cooling and continuous run are all field selectable. Refer to *Electrical* section for description.

Heating Cycle

1. Thermostat calls for heat, connection is made between the (“R” terminal) red and white (“W” terminal) thermostat wires as set up by installer.
2. Corresponding zone damper opens fully, the other zone damper, if not calling, powers to minimum open position. Heating relay is energized; providing power to relay A1, circulating pump connection point. After “15

second delay” to allow plenum to warm up, fan motor starts at value selected by installer and corresponding W1 input. Only upon call for second zone and after timed default will the fan increase to the W2 value.

3. If R + D (optional aquastat circuit) are interrupted, motor remains at continuous low input value until circuit is made.
4. When the zone temperature is satisfied, the zone thermostat breaks connection between “R” and “W”. The off zone damper returns to the minimum open position.
5. When both thermostats are satisfied ,the relays are de-energized; pump

stops, zone dampers revert to their full open position, fan shuts off after a pre-programmed purge delay (or switches to continuous run speed when continuous run (Fan On) is employed at the thermostat).

Cooling Cycle

- 1 Zone thermostat calls for cooling, connection is made between (“R” terminal) red (“G” terminal) green and (“Y1” or “Y2” terminal, factory bridged) thermostat wires, as selected by the installer.
- 2 Corresponding zone damper opens fully, other zone damper (if not calling) powers to minimum open position and the cooling condenser circuit is energized provided field supplied freeze thermostat is closed.
- 3 After Time delay fan motor starts at value selected by installer and corresponding “Y1” or “Y2” input

- 4 When room temperature is satisfied, thermostat breaks connection between “R”, “G” and “Y1” / “Y2” wires.
- 5 When both zone temperature are satisfied the cooling condenser circuit is de-energized, the zone dampers revert to the full open position and the fan shuts off (or switches to continuous run speed when continuous run (Fan On) is employed at the thermostat).

Continuous Run Cycle (Fan ON)

- 1 Zone thermostat connection is made between (“G” terminal) green and (“R” terminal) red.
- 2 Corresponding zone damper opens fully, the other zone damper, if not calling, powers to minimum position.
- 3 Continuous run relay is energized; fan input value operates on continuous run speed.

SEQUENCE OF OPERATION P3

Refer to Ladder Diagram and Wiring Schematic for relay locations.

Note: **MaxAir™** air handlers are equipped with a brushless dc fan motor. Speeds for heating, cooling and continuous run are all field selectable. Refer to *Electrical* section for description.

Heating Cycle

1. Thermostat calls for heat, connection is made between the (“R” terminal) red and white (“W” terminal) thermostat wires as set up by installer.
2. Corresponding zone damper opens fully, the other zone damper, if not calling, powers to minimum open position. Heating relay is energized; providing power to relay A1, circulating pump connection point. After “15 second delay” to allow plenum to warm up, fan motor starts at value selected by installer and corresponding W1 input. Only upon call for second zone and after timed default will the fan increase to the W2 value.
3. If R + D (optional aquastat circuit) are interrupted, motor remains at continuous low input value until circuit is made.
4. When the zone temperature is satisfied, the zone thermostat breaks connection between “R” and “W”. The off zone damper returns to the minimum open position.
5. When all thermostats are satisfied, the relays are de-energized; pump stops, zone dampers revert to their full open position, fan shuts off after a pre-programmed purge delay (or switches to continuous run speed when continuous run (Fan On) is employed at the thermostat).

Cooling Cycle

1. Zone thermostat calls for cooling, connection is made between (“R” terminal) red (“G” terminal) green and (“Y1”, “Y1/Y2” terminal, factory bridged) thermostat wires, as selected

by the installer.

2. Corresponding zone damper opens fully, other zone damper (if not calling) powers to minimum open position and the cooling condenser circuit is energized provided field supplied freeze thermostat is closed.
3. After Time delay fan motor starts at value selected by installer and corresponding “Y1” or “Y1” input
4. Only upon a call for additional zone(s), after the time delay and based on a proper plenum sensor reading will the fan value increase to “Y2” value.
5. If the plenum temperature drops the sensor will cycle the condenser to maintain the temperature above the frost point.
6. When room temperature is satisfied, thermostat breaks connection between “R”, “G” and “Y1” wires. The off zone damper(s) returns to the minimum open position.
7. When all zone temperature are satisfied the cooling condenser circuit is de-energized, the zone dampers revert to the full open position and the fan shuts off after the programmed purge delay (or switches to continuous run speed when continuous run (Fan On) is employed at the thermostat).

Continuous Run Cycle (Fan ON)

1. Zone thermostat connection is made between (“G” terminal) green and (“R” terminal) red.
2. Corresponding zone damper opens fully, the other zone damper, if not calling, powers to minimum position.
3. Continuous run relay is energized; fan input value operates on continuous run speed.

SERVICE AND MAINTENANCE

filter

The **MaxAir™** series air handlers are not provided with a filter. A good quality filter should be installed and or replaced or cleaned monthly.

A CLOGGED OR INADEQUATE FILTER MAY VOID PRODUCT WARRANTY.

duct cleaning

If proper filter maintenance is adhered to, duct cleaning is not required for the life of the equipment.

coils

Air conditioning and heating coils should not require cleaning if the filter maintenance schedule is adhered to. If a filter is damaged or collapses from plugging, the coils may get fouled by dust. If this happens, replace the filter and carefully vacuum the coils. The fan may need to be removed to gain access to

the face of the heating coil.

air conditioning coil

At the start of each cooling season, check the drain connection to the cooling coil to ensure it is free of debris. An easy way to do this is to blow into the tube to see if there is any obstruction. If a plugged air conditioning coil is suspected, call a service technician for testing and cleaning.

fan and motor

Check fan for dust once a year. If dirty, vacuum or wash to remove dust. Keeping the fan blades clean will reduce noise and improve the capacity and efficiency of the heating system. Take care to avoid wetting the motor! Remove the motor if required.

external pump

The circulating pump is water lubricated and

should require no regular maintenance. If the pump fails to start at the beginning of the heating season, follow the instructions in the *Trouble Shooting* section of this manual below.

RUNNING THE PUMP WITH THE ISOLATION VALVES CLOSED OR WITH NO WATER IN THE SYSTEM WILL DAMAGE THE PUMP

NOTE: THE MAXAIR™ FAN COILS ARE NOT TO BE USED FOR TEMPORARY HEAT DURING CONSTRUCTION. USE FOR THIS PURPOSE WILL VOID EQUIPMENT WARRANTY.

UNIT TROUBLESHOOTING

external pump does not run

In areas where hard water is present the pump may “stick” and fail to run after long idle periods. Often this can be freed by closing the isolation valve on the return leg and opening the drain port so full city water pressure flows through the pump. If this fails to free the pump, removal for cleaning or replacement is necessary.

external pump is noisy at start-up

Air is present in heating loop. If sound has not diminished within 1 minute, purge air in accordance with the *Start-Up* procedures. Check to make sure branch connections for heating loop are horizontal.

water heater T&P is weeping

A check valve or back-flow preventor has been installed in the system. Some form of pressure relief may be required.

Options are:

- Install expansion tank.
- Install pressure relief valve; locate outlet over laundry tub or floor drain.

Install combination toilet tank/pressure relief valve

insufficient or no heat

- Plugged air filter or coil. Refer to *Maintenance* section for filter care and coil cleaning.

- Air in heating loop; purge system.
- Inlet and outlet connections to air handler backwards; reverse connections.
- Restricted or improperly installed supply tube in water heater; check and replace.
- Water heater thermostat set too low or not calibrated properly; check water temperature at a faucet. If the temperature has been set low because of homeowner preference, an anti-scald valve may be needed to provide the homeowner with the means of turning the domestic hot water down without affecting the heating output.
- Restriction in heating loop; remove restriction, check valve stuck or closed valve.

cold water at hot faucet

The most probable cause is reverse flow through the heating loop from a stuck check valve; repair or replace valve.

fan runs for cooling but not heating

Thermostat may be connected improperly. Refer to *Electrical* section for proper installation.

heating during off cycle

Probable cause is thermal siphoning. See check valve description for details; repair or replace check valve. Check elevation of air handler above water heater to see if motorized valve required for positive shut-off.

24 hr pump timer cycle is engaged. Wait to ensure pump shuts off after cycle is over

(1m-15sec or 5min). Pump timer starts upon energizing of air handler with line voltage.

ZONE SYSTEM TROUBLESHOOTING

zone system checks

Solution	Action
A	Check zone panel transformer output for 24VAC, verify transformer input power
B	Mark and remove all wires except power to verify no wiring shorts exist
C	Turn all thermostats OFF
D	Turn off power and check resistance at terminals SAS1, SAS2, Sensor should read 1K to 10K
E	Mark and remove thermostat wiring. Use jumpers to verify thermostat operation
F	Mark and remove damper wiring. Check for damper wiring shorts and opens
G	Mark and remove damper wiring. Verify damper operation by powering damper directly from 24VAC source
H	Possible defective panel. Consult factory for technical support
J	Download manual or refer to zone panel inside cover for DIP switch setting
K	Verify voltage input to panel. Voltage input must be between 21 and 29 VAC

2 zone panel troubleshooting steps

Step	Action	Check(s)
1	Turn off power to zone panel and remove cover.	
2	Verify E-Heat switch is in off position, and DIP switches are set properly.	J
3	Ensure no zones are calling by turning all thermostats off.	
4	Apply 24 VAC Power to the 140202 2 Zone panel.	A
5	Verify green power LED near 24 VAC Terminals is lit.	A
6	Verify green heartbeat LED in middle of panel is pulsing.	A-B-H
7	Verify both zone LED's near damper terminals are green.	A-B-C
8	Switch zone 1 thermostat to heat mode, and call for heat in zone 1.	
9	Verify zone 1 damper LED is green (open) and zone 2 damper LED is red.	E-F
10	Verify heating system is operating, air is moving out zone 1 vents, and	F-G

zone 2 vents have minimal airflow.

- | | | |
|-----------|--|---------|
| 11 | Verify supply temp display measures heat change in supply air. Switch zone 2 thermostat to heat mode, and call for heat in zone 2 by raising set temperature above room temperature. | D |
| 12 | Verify zone 1 damper LED stays green (open) and zone 2 damper is green | E |
| 13 | Verify heating system is operating and air is moving out into zone 1 and 2. | E-F-G |
| 14 | Return zone 1 thermostat to the off position. Verify zone 1 damper LED turns red and zone 2 damper LED stay green. | E-F-G |
| 15 | Verify heating system is operating, air is moving out zone 2 vents, and zone 1 vents have minimal airflow. | E-F-G |
| 16 | Turn zone 2 off. Verify system fan shuts off at the end of purge cycle. | H |
| 17 | Verify all zone LED's near damper terminals are green. | E-F-G-H |
| 18 | If the outside temperature is acceptable, repeat the above steps in cooling mode. Cooling will not work if E-Heat is on. | |
| 19 | When checkout is finished, restore thermostats and retest entire system. | |
| 20 | If the above steps do not solve the problem, please contact Technical Support | |

3 zone panel troubleshooting steps

Step	Action	Check(s)
1	Turn off power to zone panel and remove cover.	
2	Verify E-Heat switch is in off position, and DIP switches are set properly. The zone panel will not cool if E-Heat is switched on.	J
3	Ensure supply temp sensor is wired to terminals SA1 and SA2. Dampers will not close and the zone panel will not stage if the SAS is missing or damaged	D
4	Ensure no zones are calling by turning all thermostats off.	
5	Apply 24 VAC Power to the 140303 3 Zone panel.	
6	Verify green power LED near 24 VAC Terminals is lit.	A
7	Verify green heartbeat LED in middle of panel is pulsing.	A-B-H-K
8	Verify all 3 zone LED's near damper terminals are green.	A-B-C
9	Verify Supply temp display shows current plenum temperature.	D
10	Switch zone 1 thermostat to heat mode, and call for heat in zone 1.	
11	Verify zone 1 damper LED stays green (open) and zone 2 and 3 damper LEDs change to red (closed).	E-F
12	Verify heating system is operating, air is moving out zone 1 vents, and	F-G

- zone 2 and 3 vents have minimal airflow.
- | | | |
|-----------|--|---------|
| 13 | Verify supply temp display measures heat change in supply air. Switch zone 2 thermostat to heat mode, and call for heat in zone 2 by raising set temperature above room temperature. | D |
| 14 | Verify zone 1 damper LED stays green (open) and zone 2 damper LED changes to green (open). | E |
| 15 | Verify heating system is operating and air is moving out into zone 1 and zone 2. | E-F-G |
| 16 | If installed, switch zone 3 thermostat to heat mode, and call for heat in zone 3. | |
| 17 | Verify air is now flowing to zone 3. | E-F-G |
| 18 | Return zone 1 thermostat to the off position. Verify zone 1 damper LED turns red and zone 2 and 3 damper LEDs stay green. | E-F-G |
| 19 | Verify heating system is operating, air is moving out zone 2 and 3 vents, and zone 1 vents have minimal airflow. | E-F-G |
| 20 | Return zone 2 and 3 thermostats to the off position. Verify system fan shuts off at the end of purge cycle. | H |
| 21 | Verify all zone LED's near damper terminals are green. | E-F-G-H |
| 22 | If the outside temperature is acceptable, repeat the above steps in cooling mode. Cooling will not work if E-Heat is on. | |
| 23 | When checkout is finished, restore thermostats and retest entire system. | |
| 24 | If the above steps do not solve the problem, please contact Technical Support. | |

WIRING DIAGRAM (P2 UNITS)

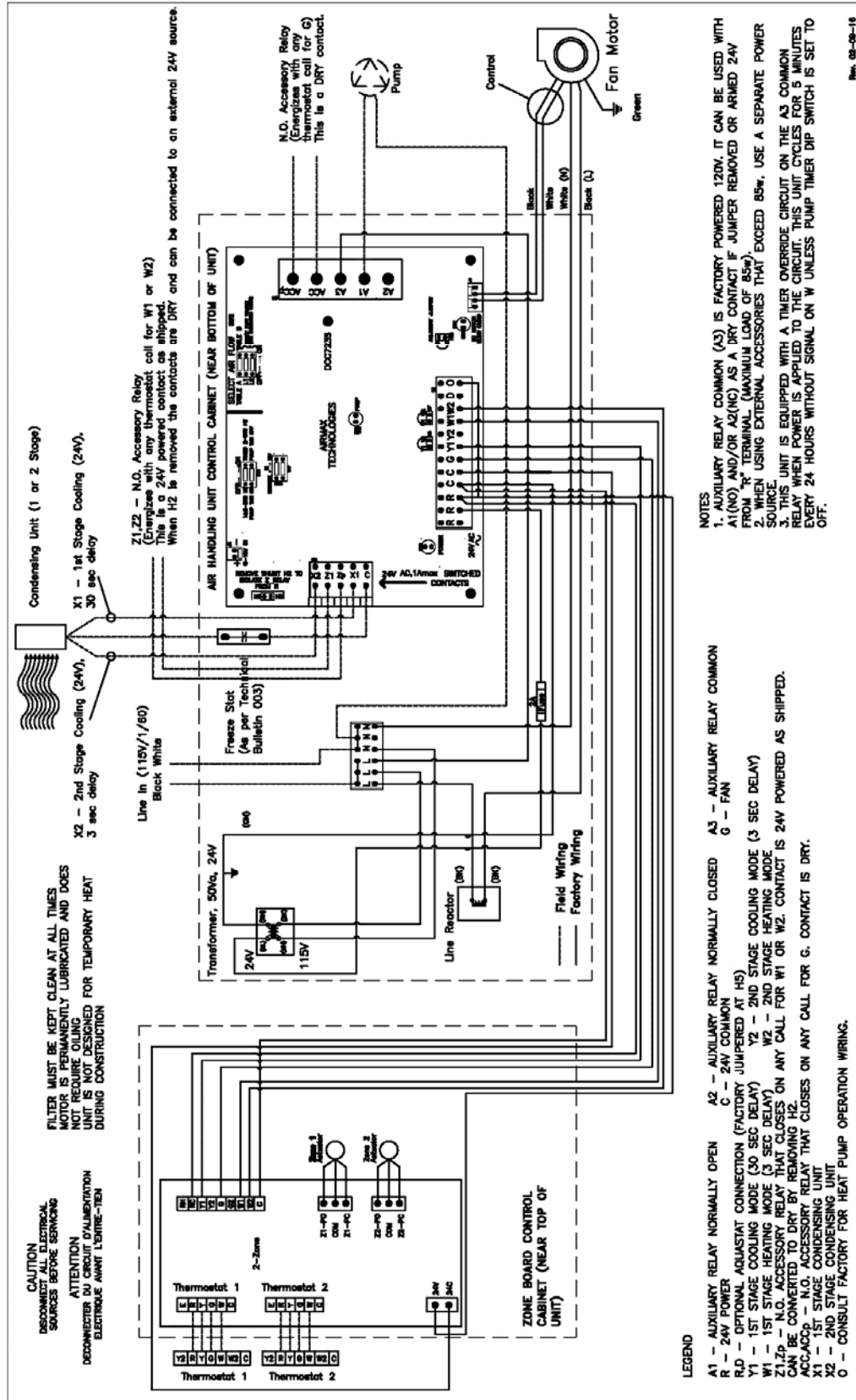

WIRING DIAGRAM (P3 UNITS)

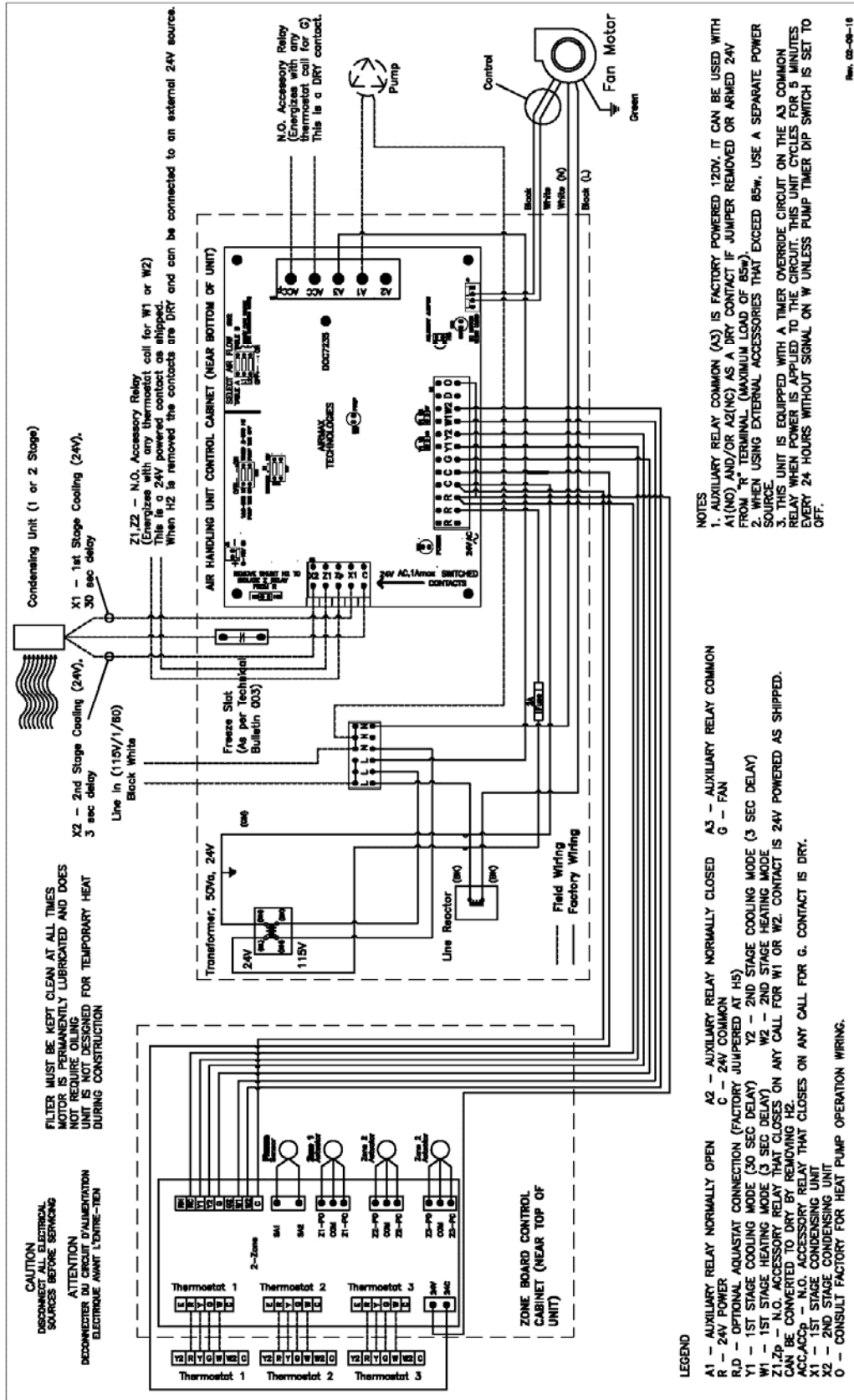

WIRING DIAGRAM (P3 UNITS) ALTERATIONS HEAT PUMP OPTION

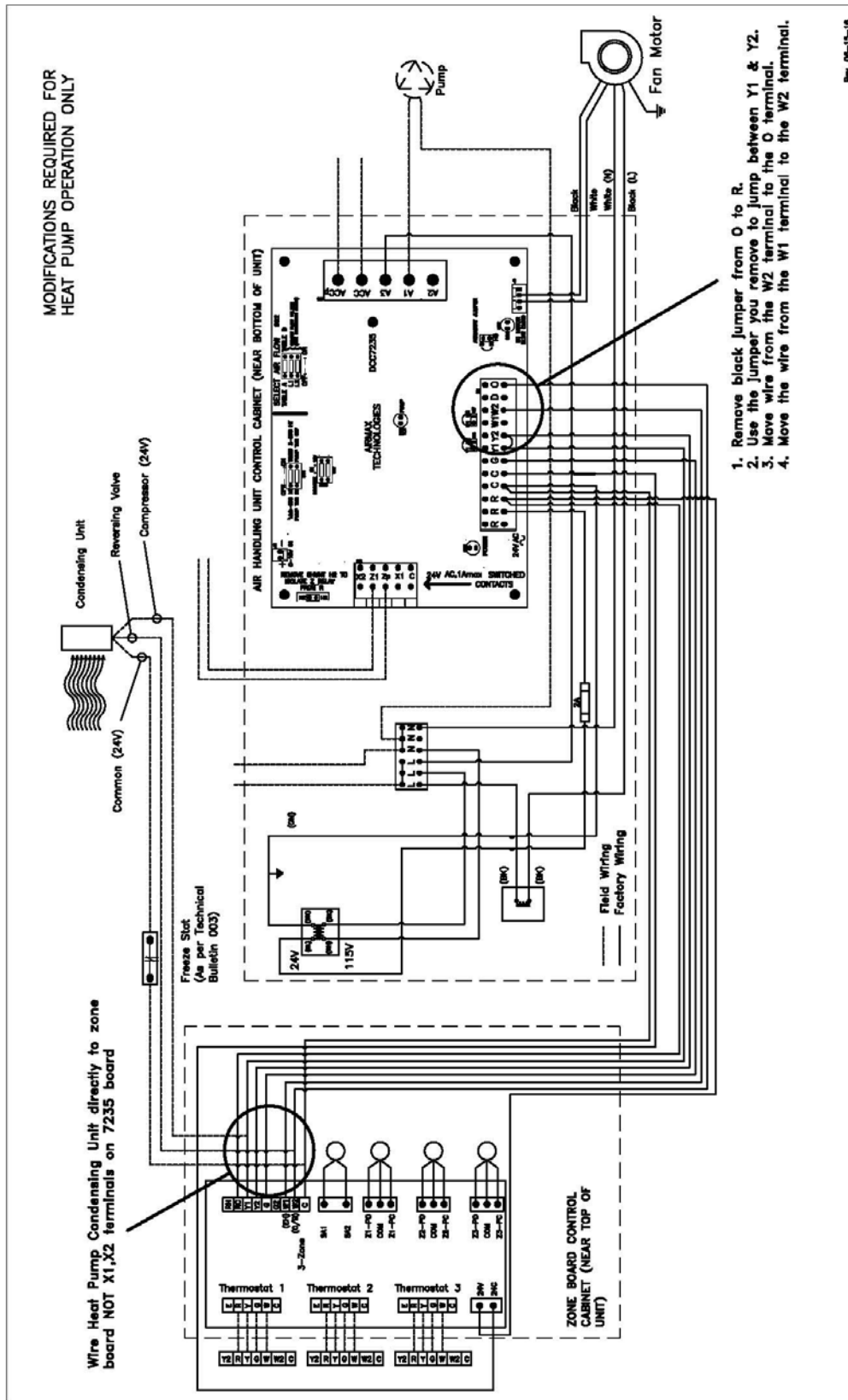

ZONE SYSTEM APPLIED WITH A HEAT PUMP CONDENSING UNIT .

It is imperative to use standard room thermostats wired to the zone board, **DO NOT** use heat pump specific thermostats.

If our zoned units are applied as a heat pump there are field modifications necessary to allow proper operation;

Two Zone

Complete wiring modification as indicated on Wiring Diagram (P2 Units) Heat Pump Option above which includes;

- Wire condensing unit to the zone board not the unit control board (DCC7235).
- Remove the black jumper from O to R at the 7235 board.
- Move the black wire from the W2 terminal at the 7235 to the O terminal (from (O/B) W2 on the zone panel).
- Move the white wire from the W1 terminal to the W2 terminal at the 7235 (from (E/H) W1 on the zone panel).

Three Zone

Complete wiring modification as indicated on Wiring Diagram (P3 Units) Heat Pump Option above which includes;

- Wire condensing unit to the zone board not the unit control board (DCC7235).
- Remove the black jumper from O to R at the 7235 board.
- Use the black jumper you removed to add a jumper between Y1 and Y2 at the 7235.
- Move the grey wire from the W2 terminal at the 7235 to the O terminal (from (O/B) W2 on the zone panel).
- Move the white wire from the W1 terminal to the W2 terminal at the 7235 (from (E/H) W1 on the zone panel).

On both models it is important the DIP settings (Page 24, tables A & B, Column Y2 & G & O and W2 & D) on the 7235 are the same for Y2 and W2 to prevent nuisance problems due to reduced air flow in heat pump heating mode.

DIP switch setting B/O is defined by the heat pump condensing unit manufacturer.

There is always a 20 minute delay before the heat pump heat is either assisted or abandoned in favor of back up heat.

Heating Sequence of Operation

Zone Board DIP Switches Set to;

1. HEAT PUMP
2. NORMAL (NOT DUAL FUEL)
3. REV VALVE "B"

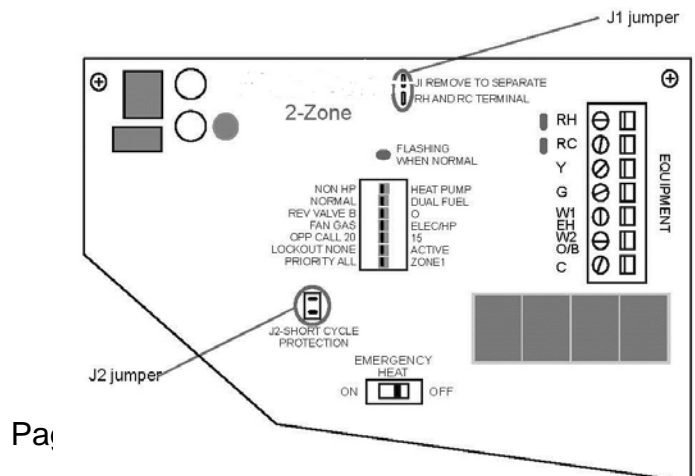

WITH “W” THE ONLY INPUT FROM THE THERMOSTAT TO THE ZONE CONTROLLER

The switch configuration results in the following output to the EQUIPMENT terminals

Y & G OUTPUTS to EQUIPMENT - **ON**

W2 O/B - **ON**

W1/EH OUTPUT - **OFF**

After 20 minutes;

Y & G OUTPUTS stay - **ON**

W1/EH OUTPUT turns - **ON**

W2 O/B STAYS – **On**

Summary: On a call for heat the compressor starts and the reversing valve is energized (heat pump condensing unit reversing valve normally in the cool position). After 20 minutes the compressor continues to run and provide heat and the back-up (hydronic heat) starts. The auxiliary heating relays close. Only if the DIP settings are the same will there be no change in airflow.

Impact on unit control board 7235;

- a. The X1 (or X2) relays activate for 20 minutes (depending on wiring). During the 20 minute period, PWM will be at Y1 or Y2 value, again, depending on the wiring. For this reason do not connect to X1 or X2 on the 7235.
- b. The O state (ON) will be interpreted by the 7235 as “cooling” mode, but only during the first 20 minutes. Since the flows programmed into the 7235 are SET the same for cooling or heating there will not be any impact on blower operation.
- c. After 20 minutes Z1 and the pump relay (A1) turns on and the X1/X2 relay will drop. This is because of the W priority programmed into the 7235.

Zone Board DIP Switches Set to;

- 1. HEAT PUMP
- 2. DUAL FUEL
- 3. REV VALVE “B”

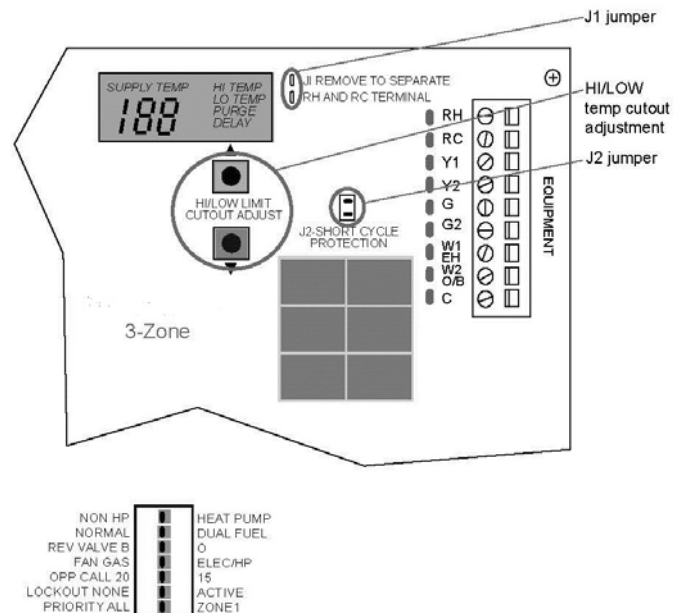

WITH “W” THE ONLY INPUT FROM THE THERMOSTAT TO THE ZONE CONTROLLER

The switch configuration results in the following output to the EQUIPMENT terminals

Y & G OUTPUTS to EQUIPMENT - **ON**
W2 O/B - **ON**
W1/EH OUTPUT - **OFF**

After 20 minutes;
G OUTPUT stays - **ON**
Y OUTPUT TURNS - **OFF**
W1/EH OUTPUT turns - **ON**
W2 O/B STAYS - **ON**

Summary: On a call for heat the compressor starts and the reversing valve is energized (heat pump condensing unit reversing valve normally in the cool position). After 20 minutes the compressor will stop and the back-up (hydronic heat) starts. The auxiliary heating relays close. Only if the DIP settings are the same will there be no change in airflow.

Impact on unit control board 7235;

- a. The X1 (or X2) relays activate for 20 minutes (depending on wiring). During the 20 minute period, PWM will be at Y1 or Y2 value, again, depending on the wiring. For this reason do not connect to X1 or X2 on the 7235.
- b. The O state (ON) will be interpreted by the 7235 as “cooling” mode. Since the flows programmed into the 7235 are SET the same for cooling or heating there will not be any impact on blower operation.
- c. After 20 minutes Z1 and the pump relay (A1) turns on and the X1/X2 relay will drop. This is because of the W priority programmed into the 7235.

Zone Board DIP Switches Set to;

1. HEAT PUMP
2. DUAL FUEL
3. REV VALVE “O”

WITH “W” THE ONLY INPUT FROM THE THERMOSTAT TO THE ZONE CONTROLLER

The switch configuration results in the following output to the EQUIPMENT terminals

Y & G OUTPUTS to EQUIPMENT - **ON**
W2 O/B - **OFF**
W1/EH OUTPUT - **OFF**

After 20 minutes;
G OUTPUT stays - **ON**
Y OUTPUT TURNS - **OFF**
W1/EH OUTPUT turns - **ON**
W2 O/B STAYS - **OFF**

Summary: On a call for heat the compressor starts and the reversing valve is not energized (heat pump condensing unit reversing valve normally in the heat position). After 20 minutes the

compressor stops and the back-up (hydronic heat) starts. The auxiliary heating relays close. Only if the DIP settings are the same will there be no change in airflow.

Impact on unit control board 7235;

- a. The X1 (or X2) relays activate for 20 minutes (depending on wiring). During the 20 minute period, PWM will be at Y1 or Y2 value, again, depending on the wiring. For this reason do not connect to X1 or X2 on the 7235.
- b. The O state (OFF) will be interpreted by the 7235 as “heating” mode. Since the flows programmed into the 7235 are SET the same for cooling or heating there will not be any impact on blower operation.
- c. After 20 minutes Z1 and the pump relay (A1) turns on and the X1/X2 relay will drop. This is because of the W priority programmed into the 7235.

FAN COIL DIMENSIONS AND RETURN AIR SIZE & LOCATION

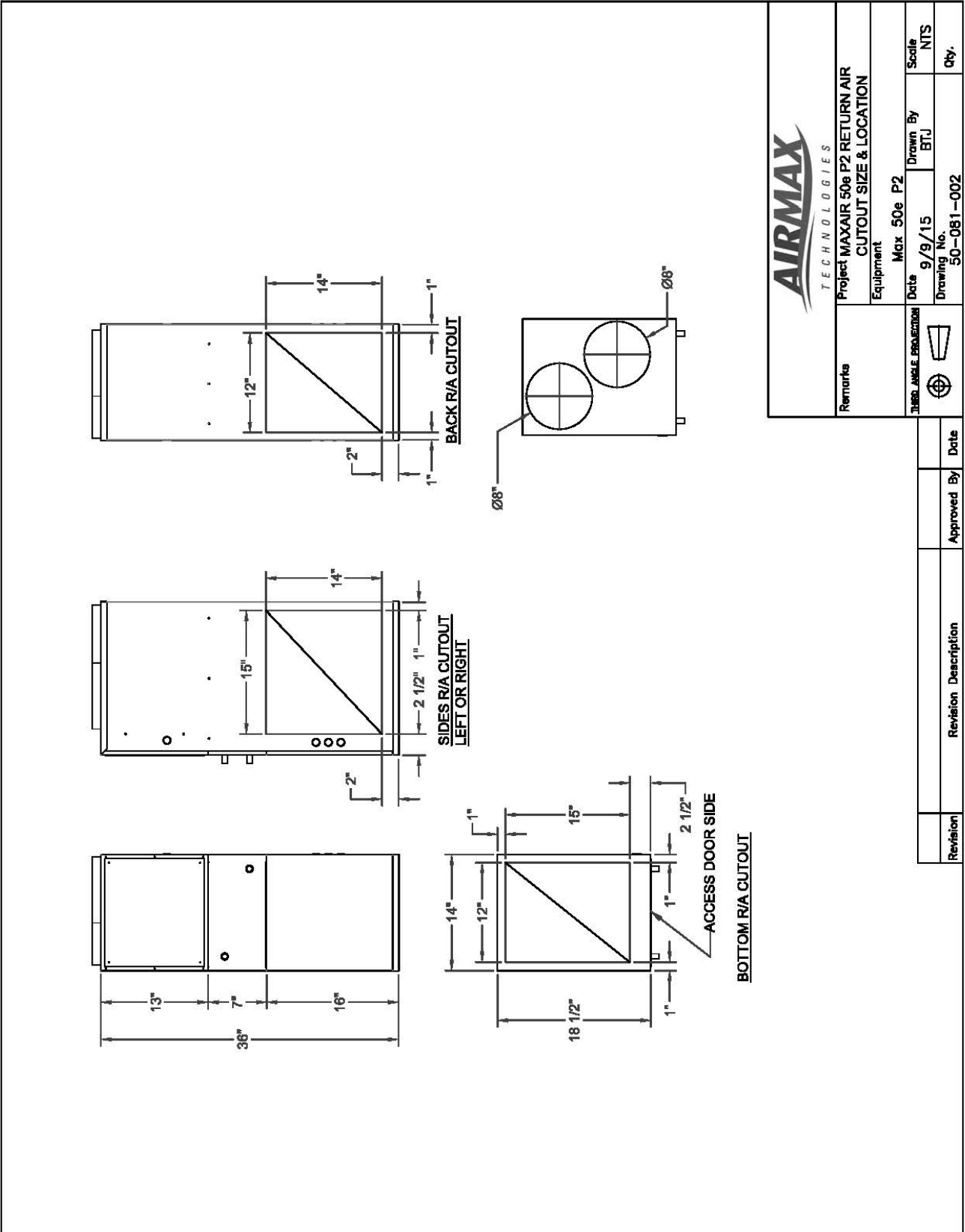

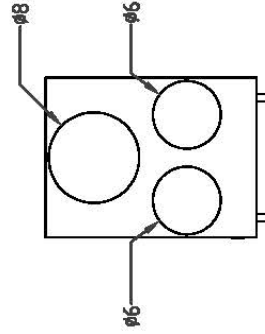
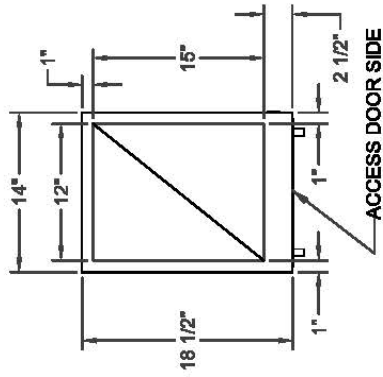
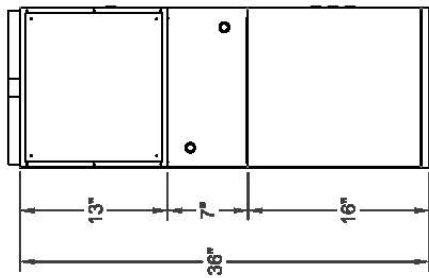
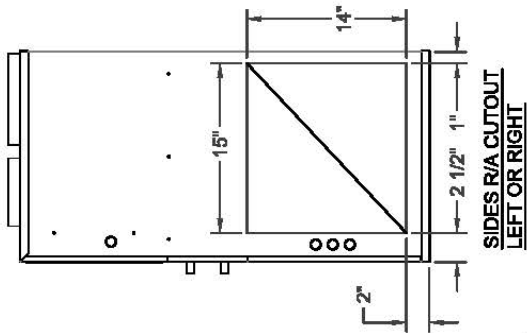
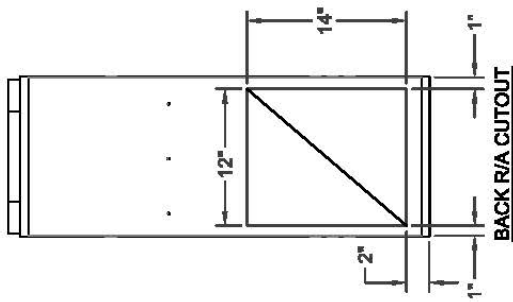

Project MAXAIR 50e P3 RETURN AIR
CUTOUT SIZE & LOCATION

Equipment Max 50e P3

Date 9/9/15

Drawn By BTJ

Scale NTS

Drawing No. 50-081-003

Qty.

Remarks



Revision	Description	Approved By	Date

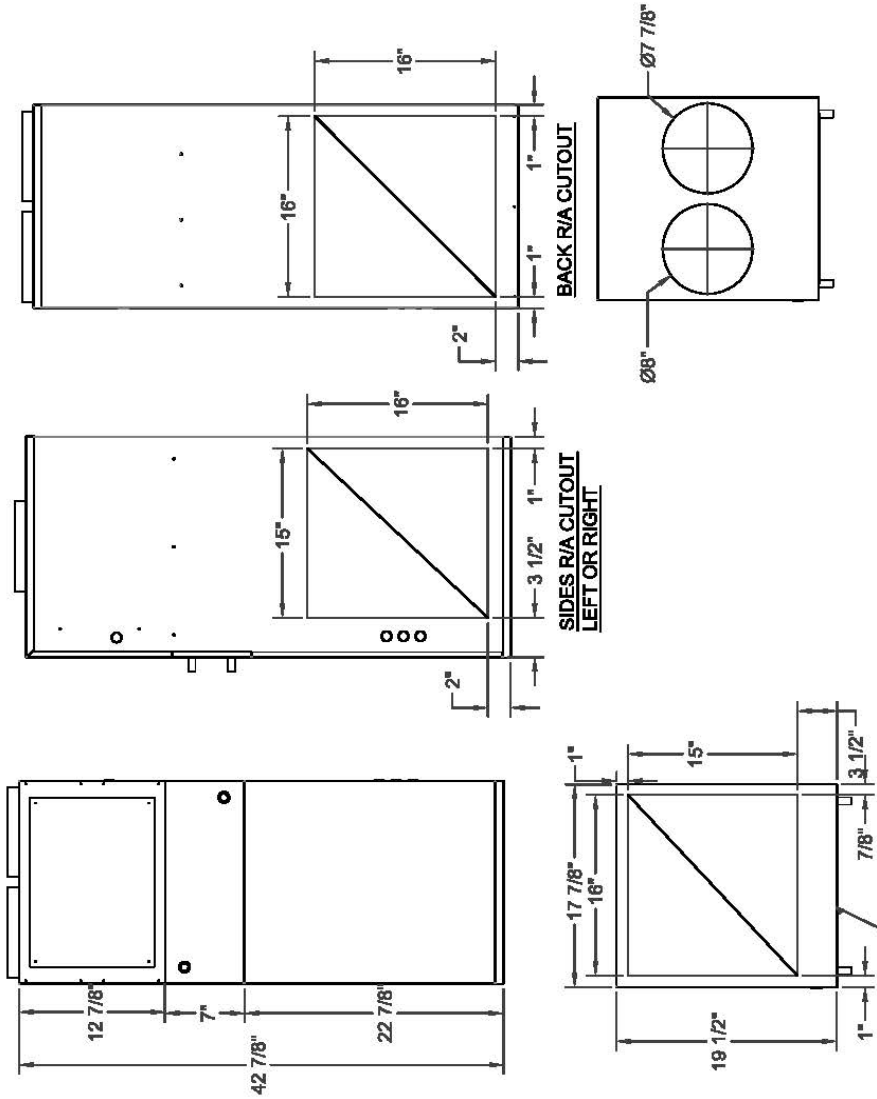

Project MAXAIR 70e P2 RETURN AIR CUTOUT SIZE & LOCATION

Equipment Max. 70e P2

Date 9/22/14 Drawn By BTJ Scale NTS

Drawing No. 70-081-002 Qty.

Revision	Description	Approved By	Date

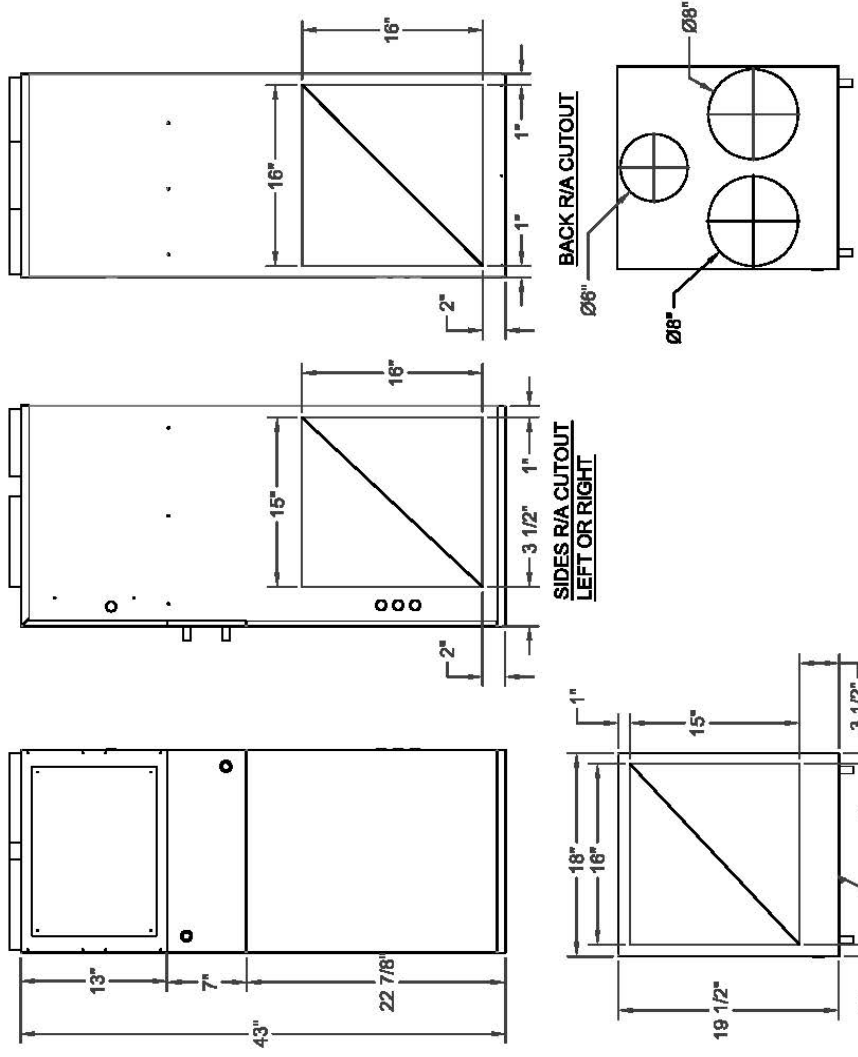

BACK R/A CUTOUT

SIDES R/A CUTOUT
LEFT OR RIGHT

BOTTOM R/A CUTOUT

ACCESS DOOR SIDE



Project MAXAIR 70e P3 RETURN AIR
CUTOUT SIZE & LOCATION

Equipment	Max. 70e P3	Drawn By	Scale
Date	9/22/14	BTJ	NTS
Drawing No.	70-081-003		Qty.

Remarks



Revision	Revision Description	Approved By	Date

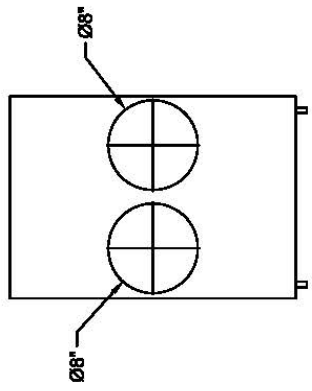
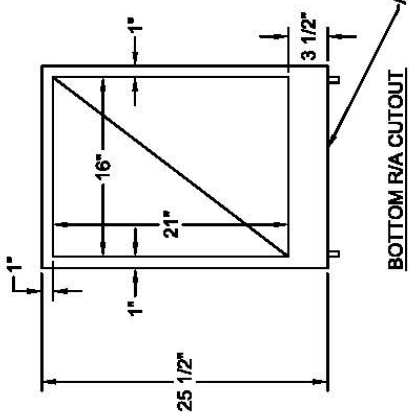
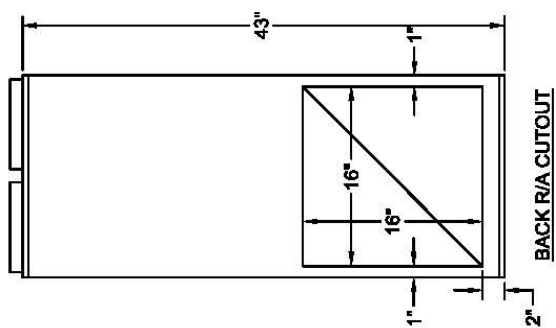
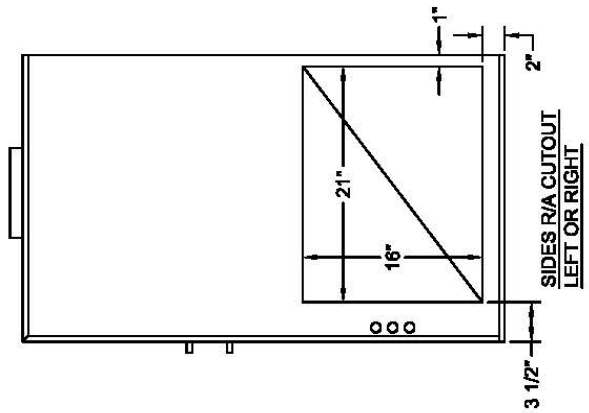
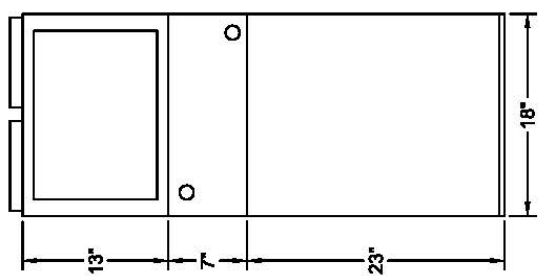

ACCESS DOOR SIDE



Project MAXAIR 100e P2 RETURN AIR CUTOUT SIZE & LOCATION

Equipment Max 100e P2

Date 9/9/15 Drawn By BTJ Scale NTS

Drawing No. 100-081-002 Qty.

Revision	Revision Description	Approved By	Date

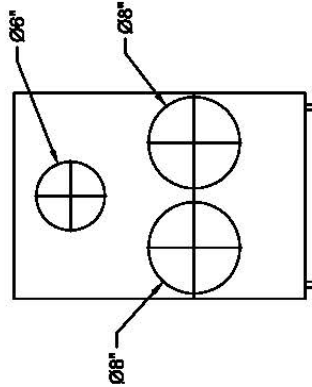
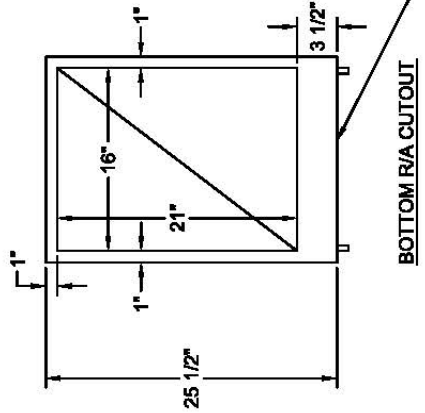
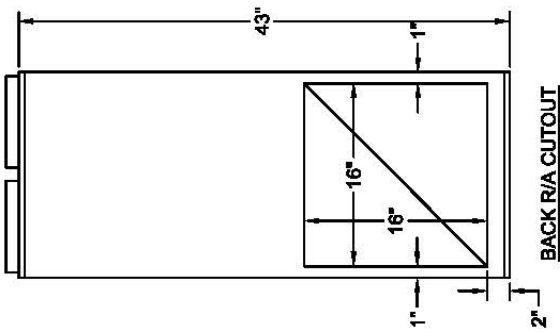
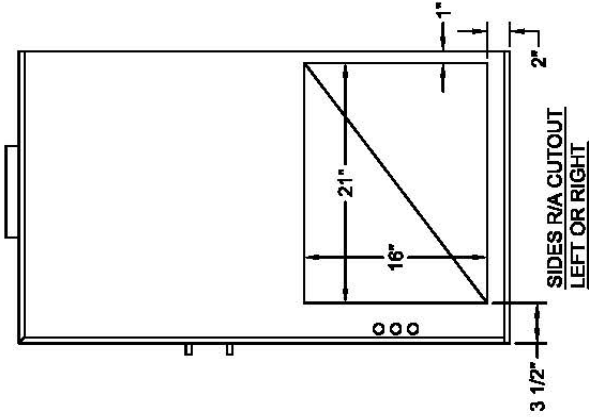
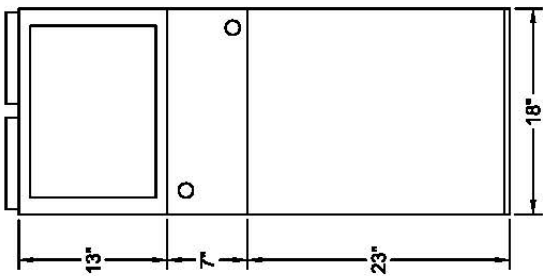

ACCESS DOOR SIDE



Remarks	Project	MAXAIR 100e P3 RETURN AIR CUTOFF SIZE & LOCATION
THIRD ANGLE PROJECTION	Equipment	Max 100e P3
	Date	9/9/15
	Drawn By	BTJ
	Drawing No.	100-081-003
	Scale	NTS
	Qty.	

Revision	Description	Approved By	Date

HORIZONTAL AIR FLOW EVAPORATOR COIL SIZES

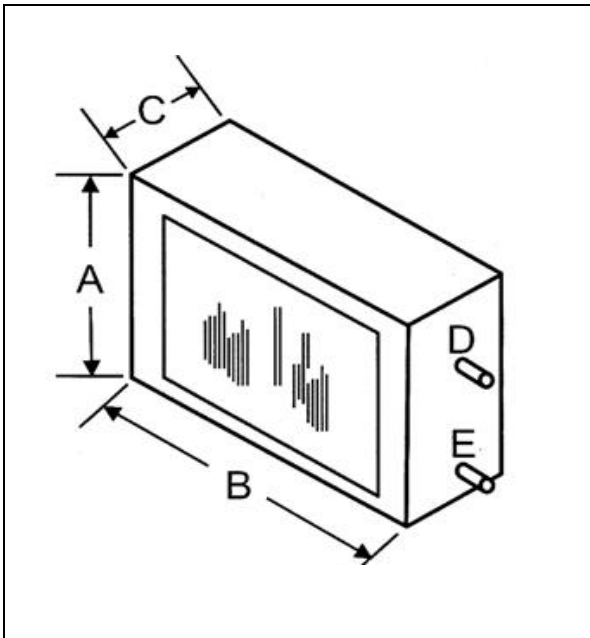

The coil module comes with a self adjusting thermal expansion valves (1T MA24-50-1– Metering device only), and an anti-ice control. The anti-ice control must be secured to the suction line as per instructions.

Note: All coils are to be sized to match the air handler.

COIL DIMENSIONS

Nominal Cooling Capacity	Model	Height (A)	Length (B)	Width (C)	Suction (D)	Liquid (E)	Weight (lbs.)	Nominal Cooling Airflow (cfm)	Coil Size
1 T	MA-24-50-1-R410-A	18"	19"	4.5"	3/4"	3/8"	15	400	11x16x2Rx10fpi
1 ½– 2 T	MA-24-50-R410-A	18"	19"	4.5"	3/4"	3/8"	15	600	11x16x4Rx10fpi
2 ½ T	MA-30-70-R410-A	18"	23"	4.5"	3/4"	3/8"	20	1000	15x16x4Rx10fpi
3 T	MA-36-100-R410-A	18"	23.5"	4.5"	3/4"	3/8"	25	1200	19x16x4Rx10fpi

All drains are ½" copper.

50/70/100 CCFF-001 COOLING COIL FILTER FRAME CABINET

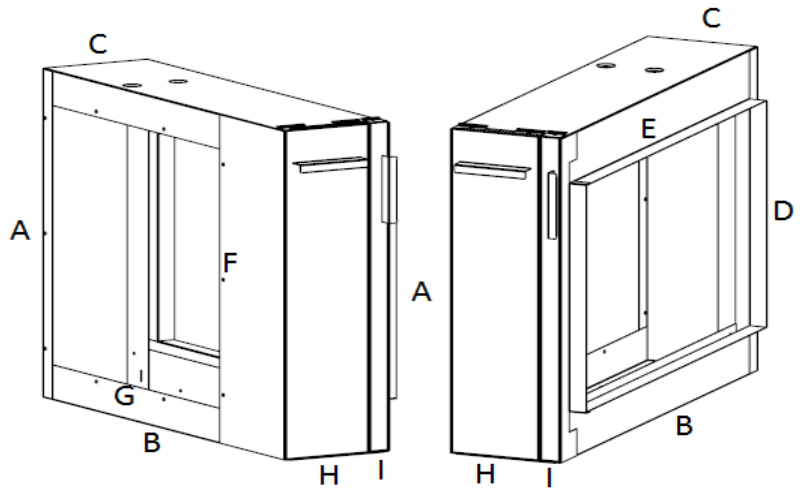

MODEL	A	B	C	D	E	F	G	H	I
50-CCFF-001	20"	20"	6 ¼"	14"	18"	15 ¾"	15"	5"	1 ¼"
70-CCFF-001	20"	25"	6 ¼"	14"	23"	15 ¾"	17 ¼"	5"	1 ¼"
100-CCFF-001	20"	25"	6 ¼"	14"	23"	15 ¾"	20 ¾"	5"	1 ¼"

Cooling Coil Filter Frame: Cooling coil filter frames accept a standard dimensional 1" filter. The coil section has dimples pressed into the top and bottom of the cabinet to ensure proper coil slope.

50-CCFF-001 cooling coil/filter frame 20" x 20" x 6-1/4" deep (accepts 16 x 20 x 1 filter), Return air connection is (14 x 18). Use with 30 & 50 series

70-CCFF-001 cooling coil/filter frame 20" x 25" x 6-1/4" deep (accepts 16 x 25 x 1 filter, Return air connection is (14 x 23). Use with 70 series

100-CCFF-001 cooling coil/filter frame 20" x 25" x 6-1/4" deep (accepts 16 x 25 x 1 filter, Return air connection is (14 x 23). Use with 100 series

SAMPLE PIPING SCHEMATICS

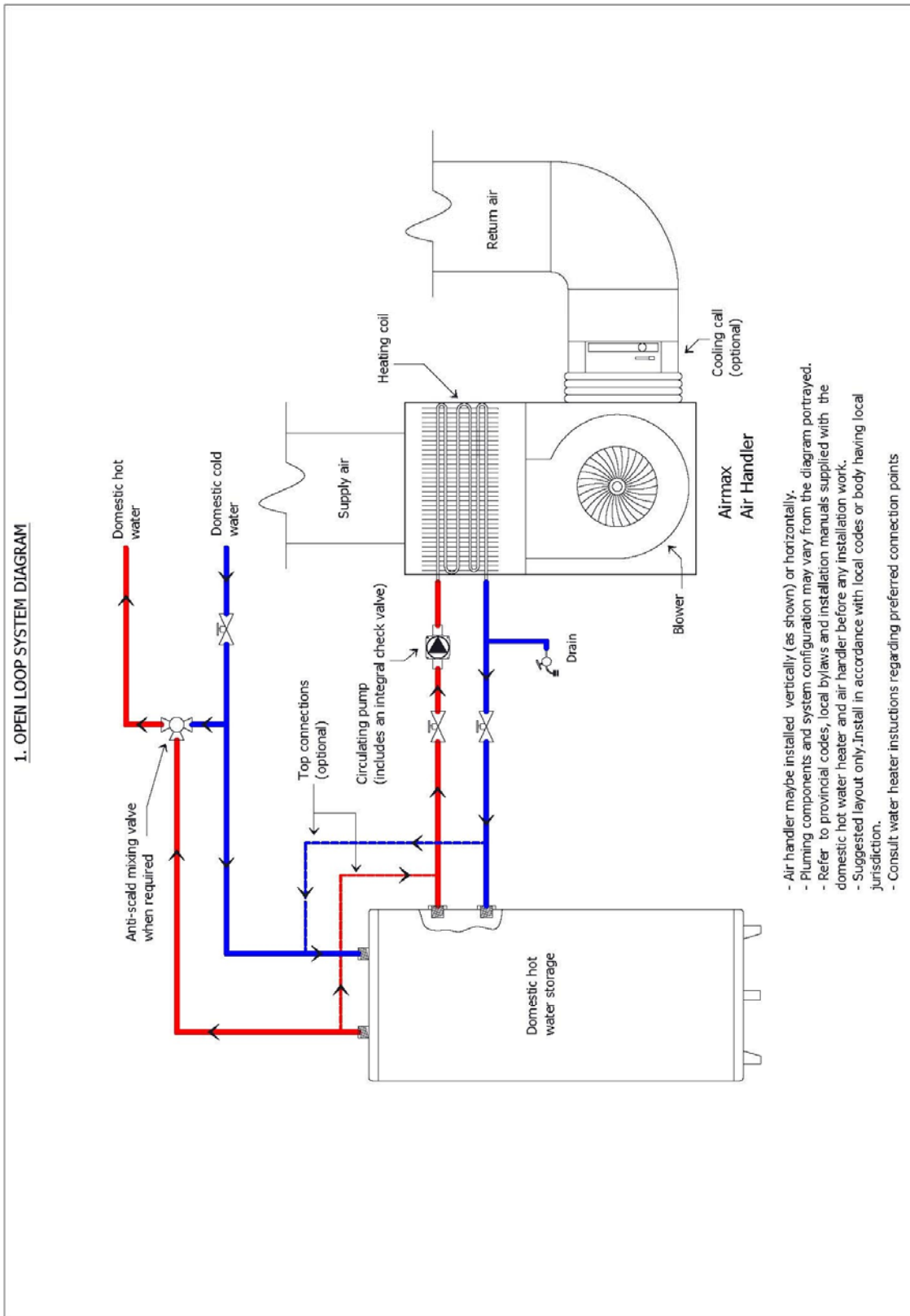

2. CLOSED LOOP SYSTEM DIAGRAM

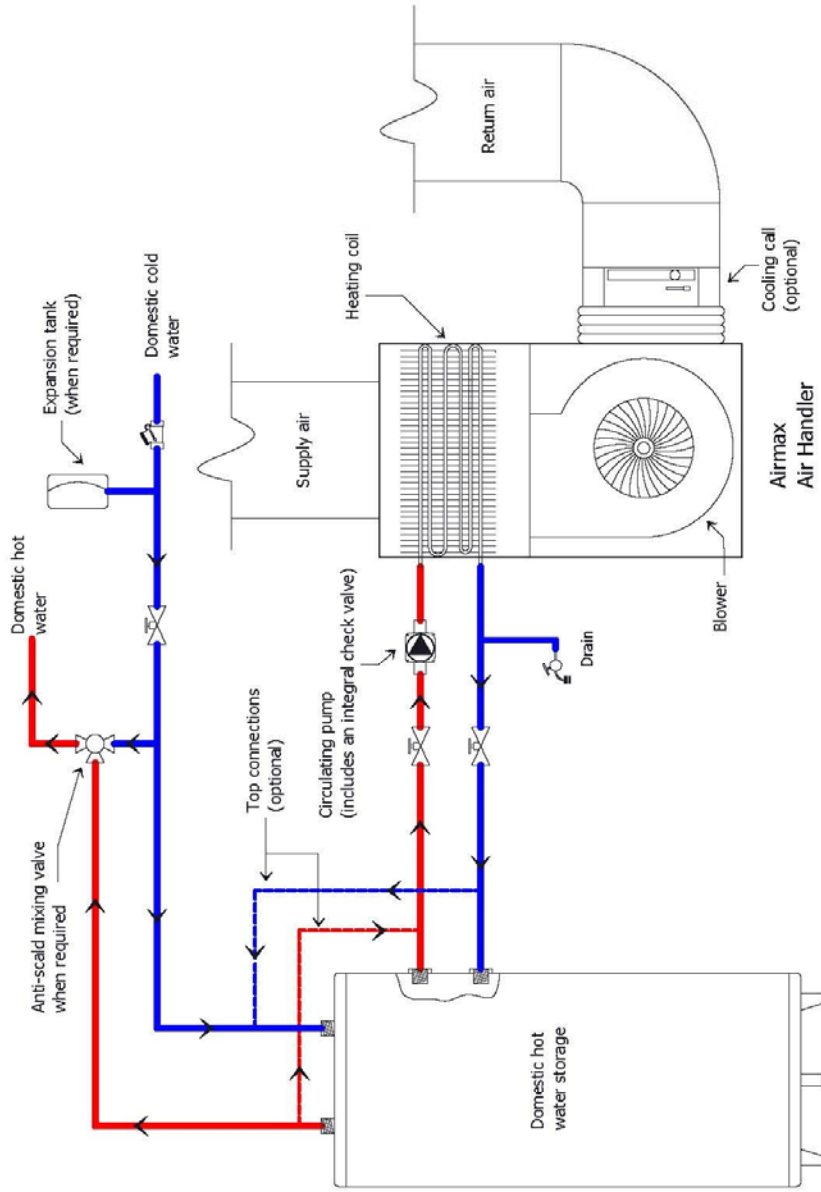

- Air handler may be installed vertically (as shown) or horizontally.
- Plumbing components and system configuration may vary from the diagram portrayed.
- Refer to provincial codes, local bylaws and installation manuals supplied with the domestic hot water heater and air handler before any installation work.
- Suggested layout only. Install in accordance with local codes or body having local jurisdiction.
- Consult water heater instructions regarding preferred connection points

3. DPWH + AIRMAX + STORAGE TANK

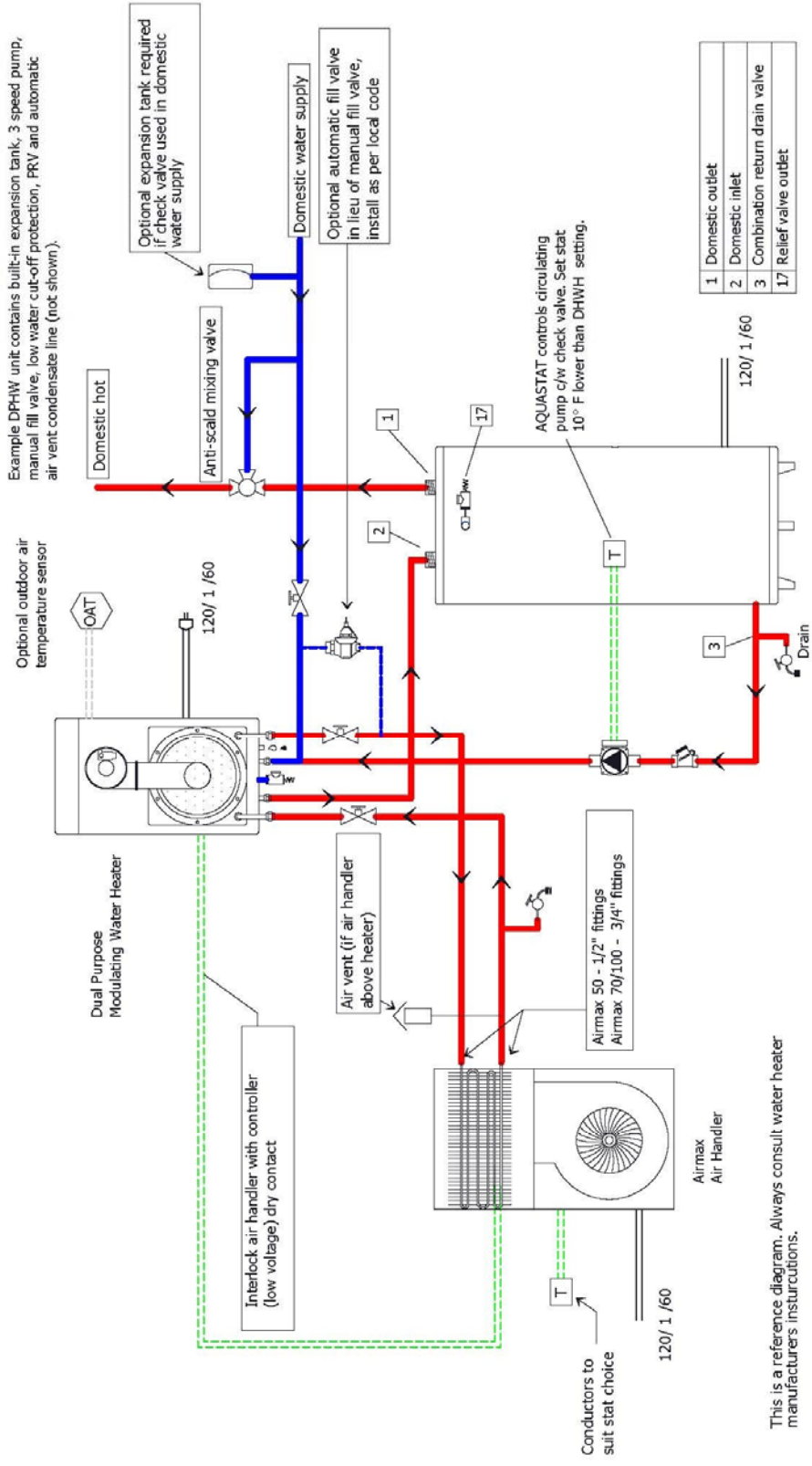

This is a reference diagram. Always consult water heater manufacturer's instructions.

This is not an engineering drawing; it is intended only as a guide and not as a replacement for professional engineering drawings. This drawing is not intended to describe a complete system. It is up to the contractor or engineer to determine the necessary components and configurations of the particular system to be installed. This drawing does not imply compliance with local building code requirements. It is the responsibility of the contractor or engineer to ensure that local building code requirements are met.

4. DPHW + AIRMAX + STORAGE TANK (PRIMARY+SECONDARY)

Example DPWH unit contains built-in expansion tank, 3 speed pump, manual fill valve, low water cut-off protection, PRV and automatic air vent condensate line (not shown).

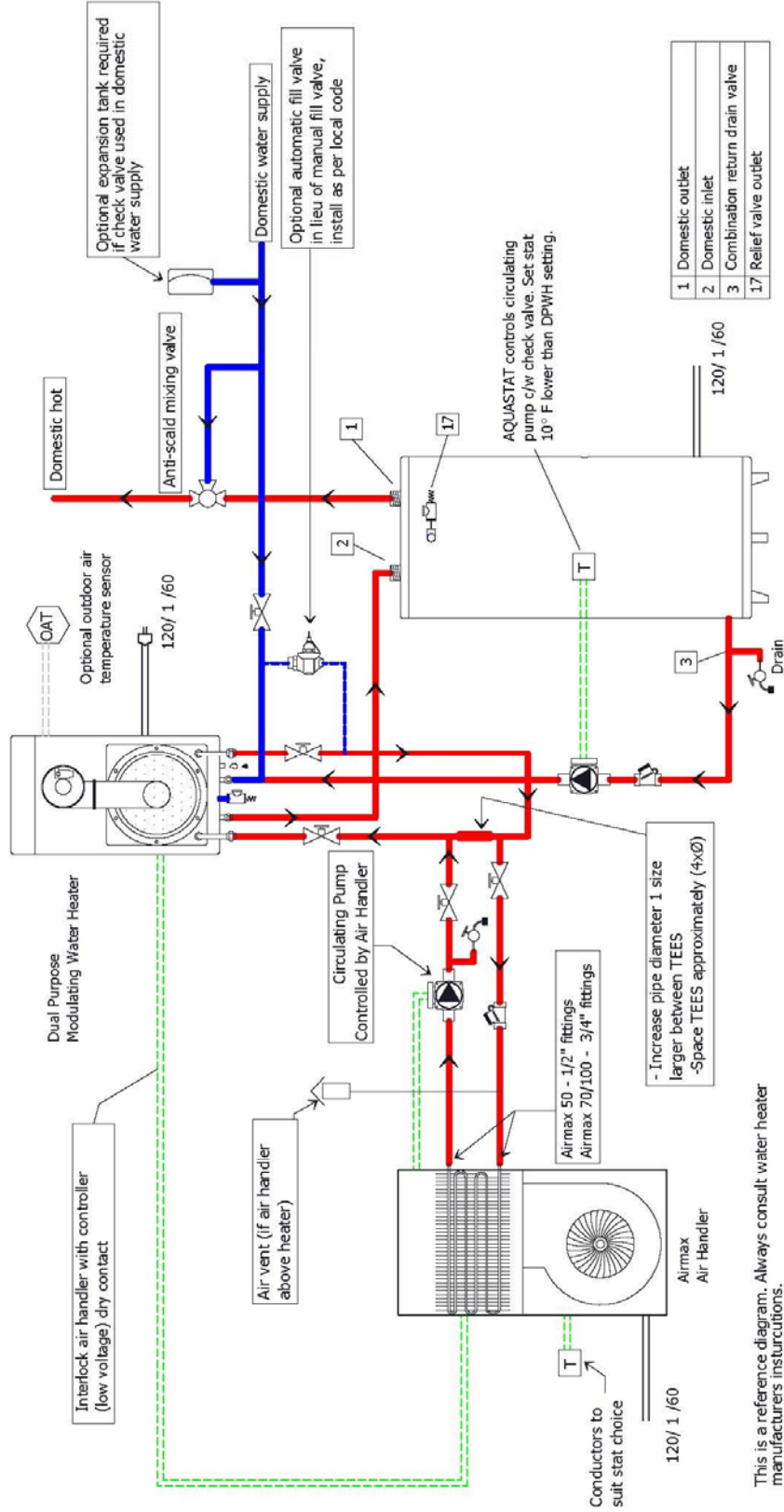

This is not an engineering drawing; it is intended only as a guide and not as a replacement for professional engineering drawings. This drawing is not intended to describe a complete system. It is up to the contractor or engineer to determine the necessary components and configurations of the particular system to be installed. This drawing does not imply compliance with local building code requirements. It is the responsibility of the contractor or engineer to ensure that local building code requirements are met.



Terms and Conditions of Sale

E-mail: info@airmaxtechnologies.com
Web Site: www.airmaxtechnologies.com

- Warranty:** Warranty period is twelve (12) months from date of purchase. Warranty includes parts and labor (check with AirMax Technologies Inc. for labor allowance rates). An extended twelve (12) month warranty is available, where applicable, at an additional cost, please consult AirMax Technologies Inc. Cost of returning the goods to AirMax Technologies Inc. is \by others. All warranty parts are to be prepaid by the customer. No warranty will be in effect until the equipment is paid for in full. Warranty on all equipment sold to customer may be suspended, at AirMax Technologies Inc.'s disgression, until the customers account is in good standing. Warranty covers defective components only. Normal wear and abuse is not covered. The customer's account will be credited only after the defective part has been examined by AirMax Technologies Inc. or the vendor and determined to be defective.
- Claims:** Claims for damages and shortages must be made within two (2) days of receipt of goods. It is the responsibility of the receiving party to check count and condition of goods. The receiving party's signature on the shipping copy of the invoice or bill of lading absolves AirMax Technologies Inc. of responsibility for count and condition unless damage is concealed. In the case of damages or shortages, it is the responsibility of the receiving party to claim against the carrier if other than AirMax Technologies Inc.
- Returns:** Written permission must be obtained for return of all goods. All returns will be subject to a 25% restocking charge. All returns are to be prepaid. When returning goods, please quote the invoice number on which the goods were purchased, product serial number, and the return goods number issued by AirMax Technologies. Special or custom order equipment may not be returned for credit. Any products or components must be returned to AirMax Technologies Inc. free and clear of liens or other encumbrances.
- Limitations on Liability:** This warranty does not cover and no warranty is made with respect to;
- Failures not reported to AirMax Technologies within the time period specified above.
 - Failures or damage due to misapplication, misuse, abuse, improper storage, improper installation, or handling, abnormal conditions of temperature, water, dirt, corrosive substances, or other contaminants.
 - Products which have been repaired with parts or materials not furnished or approved by AirMax Technologies Inc. or by its authorized dealers or representatives, or products which have been in any way tampered with or altered.
 - Products damaged in shipment or storage or otherwise without fault of AirMax Technologies Inc..
- AirMax Technologies Inc.'s total responsibility for any claims, damages, losses, or liabilities related to the product covered hereunder shall not exceed the purchase price of such product. In no event shall AirMax Technologies Inc. be liable for any special, indirect, incidental, or consequential damages of any character, including but not limited to loss of productive facilities or equipment, delay of construction schedule, lost profits, property damage, transportation, installation or removal, lost production, or personal injury whether suffered by the purchaser or any third party. AirMax Technologies Inc. disclaims all liability for any and all costs, claims, demands, charges, expenses, or other damages, either direct or indirect, incidental to personal injury or property damage arising out of any cause of action based on strict liability.
- Freight:** Prepaid and bill, FOB Factory
- Payment Terms:** 2% 10 days. Net 30 days (O.A.C.). 2% service charge will be applied to overdue accounts.
- Taxes:** All taxes extra
- All prices, terms, and conditions are subject to change without notice.



Warranty Registration

E-mail: info@airmaxtechnologies.com
Web Site: www.airmaxtechnologies.com

PLEASE COMPLETE THE FOLLOWING INFORMATION AND RETURN WITHIN 30 DAYS OF THE UNIT START UP AND INCLUDE A COPY OF THE EQUIPMENT COMMISSION FORM FOR EACH PIECE OF EQUIPMENT.

Sold To:

Company Name _____

Contact Name _____

Address _____

City _____ State/Province _____ Zip/Postal Code _____

Phone No. _____ Fax _____

Item Purchased:

Unit Model _____ Serial No. _____

Date of Purchase _____ Date of Start up _____

Installer _____

Purchased From:

Company Name _____

Contact Name _____

Signature _____ Date _____

To insure your warranty protection, please complete and return this form to AirMax Technologies Inc. attention Product Registration.



Warranty Parts Request Form

E-mail: info@airmaxtechnologies.com
Web Site: www.airmaxtechnologies.com

Homeowner Name: _____ **Date:** _____

Address: _____ Unit # _____

City: _____ Prov. _____ Postal Code: _____

Phone # _____ Other # _____

Contractor Name: _____

Address: _____ Unit # _____

City: _____ Prov. _____ Postal Code: _____

Phone # _____ Other # _____

Email: _____

Distributor / Rental Provider Name: _____

Address: _____ Unit # _____

City: _____ Prov. _____ Postal Code: _____

Phone # _____ Other # _____

Email: _____

Model Number: _____ **Serial number:** _____

Date installed: _____ Date Failed: _____ Date Serviced: _____

Failed Part Number: _____ **Replacement Part Number:** _____

Failed Part Description: _____

Reason for Failure: _____

“FAILED, NOT WORKING, DEFECTIVE” etc. is not acceptable and will be considered incomplete. Incomplete warranty forms will not be accepted or considered; only a detailed explanation of the component failure will be considered for warranty.

All parts returned must be accompanied with a completed warranty tag.