



209 Citation Drive, Units 5 & 6
Concord, ON, Canada, L4K 2Y8
Telephone (905) 264-1414
Fax (905) 264-1147

E-mail: info@airmaxtechnologies.com
Web Site: www.airmaxtechnologies.com

MaxAir™ 30(e), 50(e), 70(e), 100(e) Low Velocity (LV) Fan Coil Systems

Combination Heating/Cooling Equipment

Design, Installation and Maintenance Instructions

AirMax Technologies Mini Ducted MaxAir(e)™ fan coil systems

Important: Read and save these instructions.

Install in accordance with CEC and NEC; All wiring shall conform to CEC, NEC, and local building and electrical codes.



CERTIFIED
FAN COIL UNITS

Table of Contents

INTRODUCTION	5
BENEFITS.....	5
APPLICATIONS.....	5
PRODUCT DESCRIPTION	6
CABINET	6
HEATING COILS.....	6
COOLING COILS	6
FAN.....	6
OFF SEASON CIRCULATION	6
WATER HEATER	6
BOILER	6
ACCESSORIES	7
CHECK VALVE.....	7
CIRCULATION PUMP	7
FLOW CONTROL VALVE.....	7
EQUIPMENT SELECTION AND SIZING	7
SELECTING THE FAN COIL	9
SUPPLY DUCT DESIGN NOTES.....	9
RETURN DUCT DESIGN NOTES.....	9
INDOOR AIR QUALITY	10
COMBINATION MAXAIR FAN COILS AND HYDRONIC HEATING	10
LOW WATER TEMPERATURE SYSTEMS.....	10
INSTALLATION	11
AIR HANDLER MOUNTING	11
DOMESTIC WATER PIPING	11
ANTI-SCALD VALVE.....	12
COOLING COIL & TX VALVE.....	12
WATER HEATER/BOILER.....	12
DUCTWORK.....	12
FAN COIL PLACEMENT	13
TRUCK DUCT	13
BRANCH DUCTWORK	13
AIRFLOW.....	13
CONDENSATION.....	13
DX REFRIGERANT COOLING.....	13
CONDENSING UNIT	14
FREEZESTAT AND TX VALVE	14
EVAPORATOR COIL ASSEMBLY.....	14
REFRIGERATION PIPING	15
CONDENSING UNIT WIRING.....	15
EVACUATING AND CHARGING	15
ELECTRICAL (STANDARD UNITS)	15

THERMOSTAT	16
ELECTRICAL INFORMATION	16
CONNECTION LOCATIONS	16
CHANGING MOTOR SPEED SETTINGS.....	16
FIGURE 1 - CONNECTION LOCATIONS	16
ELECTRICAL (MAXe UNITS)	18
DCC7235 LAYOUT AND CONNECTIONS	18
POWER INPUT.....	18
CONTROL SYSTEM INPUTS	18
OUTPUTS	19
OUTPUTS WITH DIP SWITCH.....	21
TYPICAL HOOK UP	26
DIMENSIONS AND MOUNTING.....	26
START-UP PROCEDURES	26
SEQUENCE OF OPERATION	27
SERVICE AND MAINTENANCE	29
FILTER.....	29
DUCT CLEANING	29
COILS	29
AIR CONDITIONING COIL.....	29
FAN AND MOTOR.....	29
EXTERNAL PUMP.....	29
TROUBLESHOOTING	30
EXTERNAL PUMP DOES NOT RUN	30
EXTERNAL PUMP IS NOISY AT START-UP	30
WATER HEATER T&P IS WEEPING.....	30
INSUFFICIENT OR NO HEAT.....	30
COLD WATER AT HOT FAUCET	30
FAN RUNS FOR COOLING BUT NOT HEATING	30
HEATING DURING OFF CYCLE	30
WIRING DIAGRAM (STANDARD UNITS)	31
WIRING DIAGRAM (MAXe UNITS)	32
FAN COIL DIMENSIONS AND RETURN AIR SIZE AND LOCATION	33
EVAPORATOR COIL SIZES	37
50/70/100 COOLING COIL FILTER FRAME CABINET	38
SAMPLE PIPING SCHEMATICS	39
TERMS AND CONDITIONS OF SALE	43
WARRANTY REGISTRATION	44

INTRODUCTION

The **MaxAir(e)**TM line of combo air handlers is specifically designed for use in residential and commercial combination space and water heating systems (Combo Systems). Combo heating systems use the home's water heater or boiler to provide both space heating and domestic hot water, eliminating the need for a furnace.

Combo heating systems are ideally suited for single family homes, townhouses and apartments where the use of a furnace may not be feasible or where space requirements are limited. They can also be used for additions, renovations, and finished basements as a replacement for, or in addition to the existing heating system. Our air handlers are the smallest units available in their capacity range.

We provide you with the quietest operating air handler available. By using large capacity, high output heating coils, our product delivers more heating per volume of air than any of our competitors, which means warmer delivered air temperatures. Our blower fans are also the widest available in their size range, which translates into slower fan speeds to deliver the same amount of air. All these features add up to warmer, more comfortable air, quiet operation, and a satisfied customer.

Water heaters, boilers and air handlers can be purchased from a wholesale supplier, rented from your Gas Utility, or purchased from **Airmax Technologies** as part of a complete heating package.

Benefits of the MaxAir(e)TM **Low Velocity systems are:**

- Very little maintenance required.
- Can be installed in existing structures with minimal structural changes.
- Provides a quiet, draft free environment.

MaxAir(e)TM **Low Velocity systems applications:**

- Retrofit construction to add heating, cooling, humidification, or filtration to a building.
- New construction to deliver air throughout the entire building envelope.

PRODUCT DESCRIPTION

cabinet

All cabinet panels are insulated and have a tough, durable low maintenance galvanized finish inside and out for extra long life.

The air handler can be suspended with 4 resilient hanging straps. Hanging straps can be secured at all corners, using existing screw locations without fear of damaging internal components.

Cabinet dimensions are designed to provide maximum installation flexibility. Refer to installation requirements for more details.

heating coils

All heating coils are potable water grade copper suitable for use in plumbing systems. No lead solder is used in any component construction. All coils and internal piping conform to ASTM B68 or ASTM B88 standards.

High density aluminum fins provide maximum heat transfer for small coil surface. Lower air flow and higher fin density equals warmer, more comfortable air with much less fan noise than other air handlers.

cooling coils

All Airmax accessory slab cooling coils are shipped with the liquid and suction lines piped to the exterior of the unit casing. A TX valve where included, is shipped installed.

High density aluminum fins provide maximum heat transfer for minimal coil surface. Coils are sized for low face velocities to prevent carry over and the galvanized unit drain pans are below the entire coil including the return bends and suction header.

fan (standard unit)

All fans are wide body dynamically balanced for extra quiet operation.

Three speed motors allow for separate speeds for heating, cooling, and continuous run, providing the installer or home owner maximum choice of options.

Multi-directional sleeve bearing motors allow mounting in any direction for maximum installation flexibility.

fan (e unit)

Variable speed motors allow for discrete and selectable speeds for heating, cooling, and continuous fan, providing the installer or home owner maximum choice of options.

off-season circulation

An off-season circulation cycle is included on the air handler to provide periodic circulation of water through the space heating loop during periods of infrequent use.

water heater

Any properly sized gas, propane, or oil fired water heater will work in a combo heating system. Make sure the water heater being used is approved for combo applications. (Most manufacturers' heaters are approved.) Warranties are typically not affected by using a water heater in combo applications.

boiler

All **Airmax Technologies** combo air handlers are compatible for use with boilers or instantaneous water heaters. Contact your Airmax Technologies representative for specific installation details.

ACCESSORIES

check valve

Check valves serve two purposes:

- protect against back-flow of water to avoid short circuiting around the water heater during domestic water use.
- protect against thermal siphoning.

Thermal siphoning is flow of water through the space heating circuit while the circulating pump is not operating due to hot water rising by natural convection. This phenomenon is of little consequence during winter months, but during the summer this will cause overheating, interfere with air conditioning, and waste energy.

The check valve is supplied an integral part of the circulating pump.

circulating pump

Air handlers come with external, field installed pumps, for flexibility and service.

The circulating pump is matched for maximum performance for combo use utilizing a storage type water heater. Contact your Airmax representative for applications other than storage tanks.

flow control valve

An adjustable flow control valve is recommended to optimize system performance and ensure that the output from the water heater is stable. Any throttling type

valve may be used, but for convenience, **AirMax** can include a valve, at additional cost, with each air handler for field installation.

Combo heating systems function poorly if the temperature drop through the air handler's coil is not maintained between 20-30°F (11-17°C). The only way to adjust the water temperature drop through the coil to match the rated output conditions of the coil is to adjust the flow of water.

The performance relationship between the air handler and the water heater is ignored by most manufacturers. The **MaxAir(e)**TM combo fan coil system has been specifically designed to optimize the output of the water heater to which the air handler is attached.

- If the temperature drop is less than 20°F (11°C), the system has an excessive flow rate. This will cause turbulent mixing within the water heater storage tank, reducing the domestic water capacity, and creating large fluctuations in delivered water temperature.
- If the temperature drop across the heating circuit is greater than 30-40°F (17-22°C) there is inadequate flow. This will cause poor heating performance of the air handler and can cause stacking of the water heater leading to unsafe water delivery temperatures for domestic use.

EQUIPMENT SELECTION AND SIZING

This section of the manual is to assist the designer of the **MaxAir**TM Low Velocity fan Coil System in the size and location of the fan coil. To size an **MaxAir**TM system for a residence, it is necessary to have an accurate heat loss/gain done for the structure

in order to eliminate improper sizing.

After completing the room by room load calculations, select the **MaxAir**TM model unit that will properly meet the load requirements.

Table 1 Unit Performance Ratings

Model	MaxAir 30 LV	MaxAir 30e LV
Btuh Heating @180F E.W.T.	48,393	46,236
Btuh Heating @170F E.W.T.	43,938	41,983
Btuh Heating @160F E.W.T.	39,488	37,735
Btuh Heating @150F E.W.T.	35,045	33,492
Btuh Heating @140F E.W.T.	30,610	29,257
Btuh Heating @130F E.W.T.	26,186	25,031
DX Cooling (Tons) (1)	1	1
C.F.M. @ 0.5" E.S.P.	450	425
HP-RPM	¼-1,075	1/3-1,250
FL Amps @ 120/1/60	5.4	5.3
G.P.M. Flow rating	5	5
Fan Coil Size (L/W/H)	24"x14"x18 1/2"	24"x14"x18 1/2"
Supply Air Size	11" x 15 ½"	11" x 15 ½"
Return Air Size Required	12" x 14" min.	12" x 14" min.

Model	MaxAir 50 LV	MaxAir 70 LV	MaxAir 100 LV
Btuh Heating @180F E.W.T.	60,047	79,316	122,103
Btuh Heating @170F E.W.T.	54,496	71,780	110,753
Btuh Heating @160F E.W.T.	48,953	64,428	99,427
Btuh Heating @150F E.W.T.	43,422	57,098	88,132
Btuh Heating @140F E.W.T.	37,904	49,795	76,875
Btuh Heating @130F E.W.T.	32,404	42,523	65,664
DX Cooling (Tons) (1)	1 to 1.5	2	3
C.F.M. @ 0.5" E.S.P.	600	850	1300
HP-RPM	1/4-1,075	1/3-1,075	1-1,075
FL Amps @ 120/1/60	5.1	7.0	12.0
G.P.M. Flow rating	5	7	8
Fan Coil Size (L/W/H)	24"x14"x18 1/2"	30"x19 1/2"x18"	30"x25 1/2"x18"
Supply Air Size	11" x 15 ½"	15" x 16 ½"	15" x 22 ½"
Return Air Size Required	12" x 14" min.	16" x 15" min.	16" x 16" min.

Model	MaxAir 50e LV	MaxAir 70e LV	MaxAir 70e LV HO
Btuh Heating @180F E.W.T.	72,850	95,496	103,541
Btuh Heating @170F E.W.T.	66,085	86,566	93,833
Btuh Heating @160F E.W.T.	59,334	77,662	84,156
Btuh Heating @150F E.W.T.	52,601	68,790	74,518
Btuh Heating @140F E.W.T.	45,888	59,957	64,924
Btuh Heating @130F E.W.T.	39,202	51,169	55,386
DX Cooling (Tons) (1)	1.5 to 2	2 to 2.5	2.5 to 3
C.F.M. @ 0.5" E.S.P.	830	1,050	1,200
HP-RPM	1/2-1,750	1/2-1,750	3/4-1,750
FL Amps @ 120/1/60	7.7	7.7	9.9
G.P.M. Flow rating	5	7	7
Fan Coil Size (L/W/H)	24"x14"x18 1/2"	30"x19 1/2"x18"	30"x19 1/2"x18"
Supply Air Size	11" x 15 1/2"	15" x 16 1/2"	15" x 16 1/2"
Return Air Size Required	12" x 14" min.	16" x 15" min.	16" x 15" min.

Model	MaxAir 100e LV	MaxAir 100e LV HO
Btuh Heating @180F E.W.T.	136,268	153,390
Btuh Heating @170F E.W.T.	123,548	139,150
Btuh Heating @160F E.W.T.	110,862	124,941
Btuh Heating @150F E.W.T.	98,216	110,768
Btuh Heating @140F E.W.T.	85,621	99,791
Btuh Heating @130F E.W.T.	73,087	82,565
DX Cooling (Tons) (1)	4	4
C.F.M. @ 0.5" E.S.P.	1,700	1,600
HP-RPM	1-1,800	1-1,800
FL Amps @ 120/1/60	11.6	11.6
G.P.M. Flow rating	8	8
Fan Coil Size (L/W/H)	30"x25 1/2"x18"	30"x25 1/2"x18"
Supply Air Size	15" x 22 1/2"	15" x 22 1/2"
Return Air Size Required	16" x 16" min.	16" x 16" min.

(1) Smaller condensers maybe matched to fan coil when required (match TXV to condenser size)

Selecting the fan coil

Once the heat load and the corrected number of outlets required is known for the job you can then finalize the model of the **MaxAir™** fan coil(s) you need.

supply air duct design notes

The supply air is to be sized based on the available static pressure, and as per local

building codes and good practices.

return air duct design notes

The return air is to be sized as per local building codes and good practices. It is good design practice to line the first five feet of the return air duct with a sound acoustic insulation. This will reduce sound transfer through the duct and operating sound levels.

It is recommended to install a grill which is 10-20% larger than the return duct area to ensure adequate free area and no velocity noise at the grill. Where allowed by local codes, a single return air grill may be used. When using flexible duct for return air, use one size larger duct due to the higher friction loss.

For areas that require fresh air make-up (either direct or through an ERV or HRV), an intake may be installed in the system. Size and insulate the fresh air supply as per local code. Remember, should you install a duct that is too large, the excess fresh air will increase the system operating cost and effect overall equipment capabilities. It is recommended to install a well fitted damper into the return air plenum. The damper can then be adjusted to supply the exact amount of fresh air needed to meet local building codes.

indoor air quality

The main factors of indoor air quality are air filtration, humidity control, and fresh make-up air. All of these factors can best be achieved with a continuous run fan system. It is important to have a good quality air filter for your **MaxAir™** fan coil system. Maintaining a clean air filter will increase the unit life span, allow the unit to operate efficiently and effectively, and will provide clean air for the occupants.

Humidity control is also an important factor to indoor air quality. It is acceptable to install a humidifier following the manufacturers installation requirements.

combination MaxAir™ and hydronic heating

One of the benefits of using a hydronic system is the versatility that you have when designing the heating system. Radiant underfloor heating is an excellent system, but it does have limitations. You cannot have cooling, air filtration, and humidification with a

radiant heating system.

It is in rooms such as this that a hybrid system of both radiant heating and a **MaxAir™** fan coil would be the optimum system to provide comfort conditioning. This will provide the homeowner with good indoor air quality, and warm floor comfort.

One of the most common approaches to heating with a hybrid system is using the **MaxAir™** fan coil to provide the comfort conditioning for the main floor (and second floor if applicable) and radiant tubing in the basement and tile areas. A few outlets located in the basement is recommended in order to provide good air circulation and supplementary heating if required.

low water temperature systems (combo systems with conventional hot water tanks + geothermal systems)

Operating **MaxAir™** fan coils in a low temperature system, care must be taken when designing and installing the system. Due to the lower air temperatures, when installing ductwork in an unconditioned space, extra insulation is recommended in order to maintain a consistent air temperature at the outlets. The main supply plenum must be insulated and wrapped with a vapor barrier in order to meet local codes. All duct work should then be covered with another layer of insulation. Due to the fact that with lower water temperatures you get a lower supply air temperature, it is imperative that the water temperature is known at the design stage. If possible, a higher tank setting should be used, and an anti-scald valve be installed for the domestic use. The higher water temperature will increase system capacity, and the anti-scald valve will reduce the risk of scalding. Since some areas have specific regulations regarding combo systems, check your local building code for details on water tank temperatures, tempering valves, and pump timers.

cooling coil capacities

Possible cooling coil capacities are given in the Table 1.

INSTALLATION

The installer must adhere strictly to all local and national code requirements pertaining to the installation of this equipment.

Detailed instructions are shipped with all accessory items and should also be followed in detail.

air handler mounting

The **MaxAir(e)**TM combo air handler can be installed in most configurations. Some precautions must be observed for some of the possible mounting positions.

For installations where the access door faces up or down ensure the external circulating pump is not mounted with its shaft in the vertical position. The pump shaft must be mounted horizontally to avoid damage during operation.

The air handler can be mounted by securing straps through any of the existing screw holes in the cabinet. Should the existing screw be too short for securing a mounting strap, a longer screw can be used provided care is taken not to damage any internal components.

When fastening straps using screws, special care should be taken in the vicinity of the coil to avoid tube puncture.

The cabinet is designed so that the return air can be located on either side of the cabinet, through the bottom of the cabinet, or from the back. Position the filter rack so that the filter is readily accessible.

Install the air handler with the door firmly screwed in place to make certain the cabinet is mounted without racking. Provide at least 24 inches of service access clearance in front of the access panel of the air handler. zero clearance is acceptable on all other faces.

domestic water piping

Install a ½" (12mm) sediment faucet for use as a drain/purge valve. The drain valve must be located downstream of the pump and check valve, and upstream of the isolation valve (if isolation valve is present). This arrangement will allow any air trapped in the system to be easily flushed out. Follow the instructions in the *Start-up & Troubleshooting* sections.

Isolation valves are recommended, but not required. Installing isolation valves facilitates easy servicing and ensures positive purging of the system during start-up.

The isolation valves, if installed in the system should not be used as a throttling valve.

All joints in copper pipe must be lead free solder. All piping must be suitable for potable water use. All pipe & pipe connections shall comply with local building codes.

When soldering, special care should be taken to not overheat the water connections on the unit. Use a wet rag or heat absorption compound to prevent excessive heat buildup.

Maximum pipe lengths for all **MaxAir(e)**TM combo air handlers can be calculated using the information in the Design Manual.

When both top and side connections are provided on the water heater, recommendations of the manufacturer or supplier should be followed regarding connection.

When the space heating loop connections are made to the domestic water connections:

- the heating loop connections should be positioned horizontally in a vertical section of the domestic water line for both inlet

and outlet. Refer to the suggested piping schematic for details.

- connect the heating loop to the domestic water connections as close to the water heater as possible.

Avoid sections of pipe in the heating loop that can trap air where possible.

It is usually impossible to install a system without having at least one part of the system or heating coil able to trap air. This will not be a problem if the connection to the domestic water lines is made properly, and the system is properly purged on set-up:

- The circulating pump is capable of removing small amounts of entrained air from the heating loop.
- Following the flushing procedures in the *Start-up* section will ensure that there is no air in the system after initial set-up.
- Proper connections between the domestic water lines and the heating loop will ensure that any air that collects in the water tank, does not make its way into the heating loop.

Inclusion of air bleed valves at high points of the heating system can be included but are to be specified by the plumbing designer.

cooling coil & TX valve

The Airmax accessory slab cooling coil is shipped loose. A factory installed TX valve where applicable, is shipped with the cooling coil. The TX valve is installed onto the distributor and an external equalizing line is piped into the suction line. Detailed instructions on the TX valve and the location of the external equalizing line and sensing bulb are available from your **MaxAir™** dealer.

When brazing care should be taken to not overheat the connections on the coil. Use a wet rag or heat absorption compound to prevent excessive heat buildup.

Once the brazed connections cool down, apply a bead of silicone sealant to the copper

pipes where they pass through the rubber grommet. This will prevent air leaks and air noise.

The **MaxAir(e)™** fan coils with the accessory external cooling coil option are a draw through design. The drain pans have to be trapped to avoid air losses. The proper height of the trap is 2 times the internal static in the unit casing. For most applications a trap height of 3" is acceptable. This is the minimum distance between the trap outlet and the bottom of the trap. The trap inlet should be higher than the outlet to allow for proper drainage.

Important: Fill trap with water before running the unit.

It is acceptable to vent the trap in situations with insufficient height and clearance.

In applications where a fan or motor body block the cooling coil face a space should be left between the cooling coil discharge face and the fan coil to avoid excessive and uneven coil velocity.

water heater/boiler

Follow the water heater manufacturer's instructions for installation and start-up of the water heater. Make sure the water heater is turned off during air handler installation and service. Ensure the water heater has been refilled, and all air is purged from the system before turning on the water heater.

duct work

To minimize fan noise in the living space, it is recommended that the first five feet of return air duct be lined with acoustic insulation, when the duct directly communicates with the living space.

Return and supply air duct work should be the same size as the air handler openings up to the first branch, fitting or transition.

Warning! Special care should be taken in the vicinity of the coil to avoid tube puncture. Screw into opening flange instead of top of

cabinet when fastening the supply air duct.

Engineered duct design guidelines are based on a nominal external static pressure of 0.5" WC.

fan coil placement

The **MaxAir(e)**TM fan coil unit is to be placed according to the layout supplied by the designer. If a change in location is required, the person responsible for the design is to be consulted. The fan coil unit can be located in a horizontal or vertical position.

The location of the fan coil is not as critical as it is with conventional low velocity systems. Location of the fan coil unit will depend on:

- Minimizing all duct runs.
- Maximizing usable floor space.
- Reducing structural changes.
- Serviceability and access to the unit.
- Location of heat/cool source to fan coil.
- Available space in mechanical room.

When suspending the unit from the ceiling, it is recommended to use spring vibration isolators at each corner of the fan coil unit. This will provide a secure means of hanging the unit, and will also reduce any transfer of vibration into the building structure. Rubber belting is also acceptable. Another common means of suspending the fan coil is with angle iron, sheet metal channel, or uni-strut placed underneath the unit, and supported by threaded rod. If this method is used, isolators (rubber or equivalent) must be placed between the fan coil unit, and the support.

Ensure that the hanging method does not hinder any piping, electrical runs, filter access, or blower access.

trunk duct

Inspect the location for the trunk duct as per the duct layout for the home or building. An important consideration in placement of the main supply plenum is that the fan coil unit must be connected to the main supply plenum. Therefore, it is necessary to have a

clear path from the fan coil unit to the main supply plenum.

branch ductwork

After securing the take-off to the trunk duct, be sure to eliminate any air leaks.

airflow

Once all the ducts are installed, the airflow from the vents should be checked. If you have vents that are not blowing strongly, there are a few things to check. Make sure that the branch duct is not blocked. Check for air leaks in the ducts, and seal all leaks with tape or duct sealant, as per local codes.

condensation

On units supplied with an Airmax Accessory slab external cooling coil, a drain connection is provided on the cooling coil. A drain line, with a trap must be installed (*the size of the trap is discussed in the previous section*). For cooling installations where the fan coil unit is installed in hot, humid areas, condensate may form on the outer cabinet of the unit. When this potential exists, a secondary drain pan should be installed under the entire unit. This pan should also extend under the piping connections and TX valve. This is especially critical in attic installations where condensate can cause damage to the ceiling

DX refrigerant cooling

When installing the fan coil, either in the horizontal or vertical position, make certain that the unit is installed level in order to handle condensate drainage. The condensate drain should be trapped, and the drain line sloped toward the drain at a 1/4" per foot slope. Ensure that no screws puncture the drain pan.

The Airmax Accessory slab coil must be installed in a vertical position (horizontal airflow through the coil) or condensate drainage problems will result. It is acceptable use a field supplied "A" type evaporative coil .

Some building codes call for a secondary drain pan under the entire unit. Check local codes for more information. Any installation that has the potential of property damage due to condensate should have a secondary drain pan installed. If the unit is installed in a high heat and/or humidity location, extra insulation around the unit casing may be required to prevent excessive condensate from forming on the outer surface of the casing. Install the unit so that there is adequate clearance on all sides for service and for piping runs.

When connecting the refrigerant lines to the cooling coil, installations instructions with the coil should be followed. It is also recommended, but not mandatory that you install a sight glass and filter/drier at the condensing unit, as well as both high and low side access ports. This is useful for both the system setup, and for future trouble shooting.

Care must be taken when mounting the Airmax Accessory slab coil directly to the side of a Airmax vertical airflow fan coil. This is acceptable only on the side of the fan coil opposite the fan motor end. If mounting the coil on the side where the end of the fan motor is located use a short spacer fitting to move the coil face away from the back of the motor housing. Failure to do so will cause excessive or non-uniform velocity across the coil surface and may cause condensate carry over into the fan coil cabinet.

condensing unit

Locate the outdoor unit in a suitable location, as close as possible to the fan coil. Maintain the clearances recommended by the condensing unit manufacturer's installation manual to ensure proper airflow. The outdoor unit must be installed in a level, properly supported location. A sight glass and liquid line filter/drier is recommended but not mandatory.

freezestat and TX valve

MaxAir™ accessory DX evaporator coils

come with an anti-ice control frost thermostat (see appropriate wiring diagram) installed on the suction line. Ensure that the TXV bulb and the frost thermostat control are fastened securely and are well insulated. **DO NOT** use a self-tightening clamp on the frost thermostat as excessive tightening may damage the thermostat.

The remote sensing bulb for the TX valve should be located on a clean, **horizontal** section of the suction line. It should be mounted on the top half of the pipe in the 2 o'clock or 10 o'clock position.

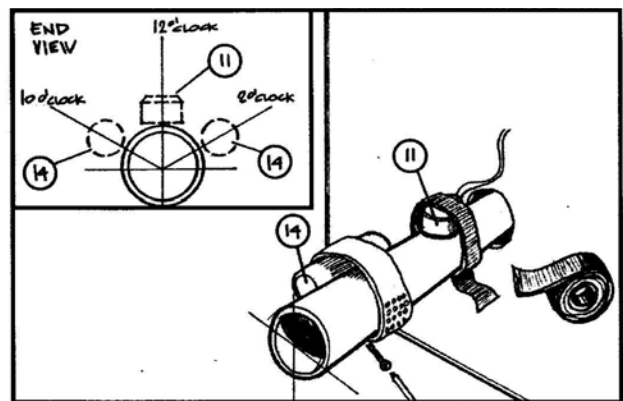

evaporator coil assembly

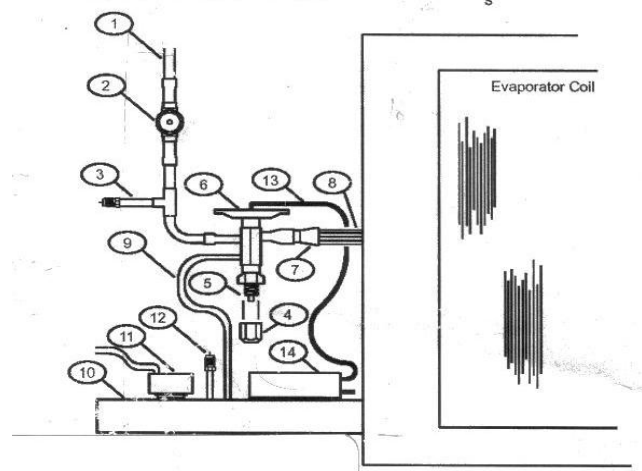

- 1) Liquid line
- 2) Site glass (not Supplied)
- 3) High side access port
- 4) Adjustment stem cap (not applicable)
- 5) Superheat adjustment stem (not applicable)

applicable)

- 6) Thermal expansion valve(TXV)
- 7) Refrigerant distributor
- 8) Distributor tubes
- 9) External equalizer line
- 10) Suction line
- 11) Anti-ice control (Frost thermostat)
- 12) Low side access port
- 13) TX capillary tube
- 14) TX sensing bulb

refrigeration piping

Use only refrigerant grade pipe and fittings. Plumbing fittings may contain wax or other contaminants which are detrimental to the proper operation of the system. Insulate the suction line as per condenser manufacturer's instructions

Install the refrigeration lines as per local codes and good piping practices, supporting the pipe every 5 feet. Run the pipes in the most direct route possible, taking into account structural integrity and building finishing details. If the evaporator is located above the condenser, slope any horizontal runs toward the condenser and provide a trap at the evaporator to prevent liquid migration during the off cycle. If the condenser is located above the evaporator, a trap must be installed in the suction line at the bottom of the vertical riser. For long vertical risers, additional traps must be installed for every twenty feet. For lines running over 50', a suction line accumulator must be installed. Lines running over 100' are not

recommended.

Flow nitrogen at a low pressure through the piping when welding to prevent oxidation.

condensing unit wiring

Make all connections to the outdoor unit with liquid tight conduit and fittings. Most building codes require a rain tight disconnect switch at the outdoor unit as well. Run the proper size wire to the unit, and connect as per the manufacturer's recommendations. Ensure that the unit is setup for a TX valve system. If not, a hard start kit may be required.

evacuating and charging

After the piping is installed, and all components connected, pressurize the system and check for leaks. The use of an electronic leak detector is recommended, as it is more sensitive to small leaks under the low pressures commonly used for initial leak detection.

Fill the system with nitrogen to 100 psig and test for leaks. Using a good, quality vacuum pump, evacuate the system from both the low and high side of the system to 500 microns and ensure that the system holds at the vacuum pressure. If not, check for leaks and evacuate again. If the vacuum is maintained, add refrigerant to raise the pressure to 2 psig, and either open the service valves (suction first) on pre-charged condensing units, or add refrigerant to the system until the proper operating charge is obtained.

ELECTRICAL (STANDARD UNITS)

Warning! - All air handlers operate on 115v/1ph/60hz line voltage. All control circuits are 24 volt. Make certain the MaxAir™ unit is properly grounded. Locate air handler on a separate electric

circuit as per local electrical codes.thermostat

The **MaxAir™** series air handlers are compatible with any standard heat/cool, heat pump, "electric heat", "gas heat", set-back or electronic thermostat.

Thermostat Heat Anticipator Setting	0.04 amps
-------------------------------------	------------------

Thermostats without cooling: do not connect the yellow wire at the air handler.

Thermostats without continuous run switch (fan ON): do not connect the green wire at the air handler.

electrical information

The **MaxAir™** air handler wiring diagrams are located inside of the main access panel on the control panel for easy reference during installation.

Nameplate data is located on the exterior face of the blower door.

For other electrical details and schematics, please contact your **MaxAir™** representative.

NOTE: Total accessory amp draw must not exceed 1.0 Amp per CSA 236, C.I. 36.12.

connection locations

A terminal strip located inside the control panel is provided for the following electrical connections:

- Main power connection
- Circulation pump

- Thermostat
- Condensing unit
- Heating accessory
- Cooling accessory

changing motor speed settings

MaxAir™ air handlers are equipped with three speed motors.

Factory settings are:

- Cooling speed = high
- Heating speed = high
- Continuous run = low

Motor speeds for cooling, heating or continuous run are all field selectable, in any combination.

Changes to motor speeds are made at the unit control panel.

Warning! All connections are clearly marked. It is acceptable to put two or more fan relay connections under one terminal lug. (The unit comes factory set with both the continuous run and heating speed relay connections under the motor low speed terminal lug.) Do not use jumpers between terminal lugs. Connecting two or more motor taps together will result in immediate motor failure and possible fire hazard.

PSC MOTOR CONTROL BOARD



Figure 1 - Connection Locations

ELECTRICAL (MAXe UNITS)

The DCC7235 is a microcontroller-based electronic volume controller for brushless dc motor-driven fan coils, furnaces or other systems. It commands discrete or variable blower speeds, torques or airflow in heating, cooling and ventilation modes from inputs provided from a discrete or proportional thermostat or controller whose switched 24VAC signal outputs activate a blower's air volume. Discrete output blower command values are selected and scaled from tables, individually selected by dip-switches. One controller can be used with several different products of different capacities. An on-board dip-switch optionally selects a 0-10V input for variable/proportional volume control. The DCC7235 can be used with proportional, 1-stage HEAT/COOL, 1 or 2-Stage COOL, and 1 or 2-Stage HEAT thermostats.

Five relay contact outputs are available for activating accessories. Two are high voltage, dry contacts. Three others switch the 24VAC ("R") powering the controller. One of those three can be isolated from "R" by removing a shunt and providing 24VAC dry contacts.

DCC7235 LAYOUT

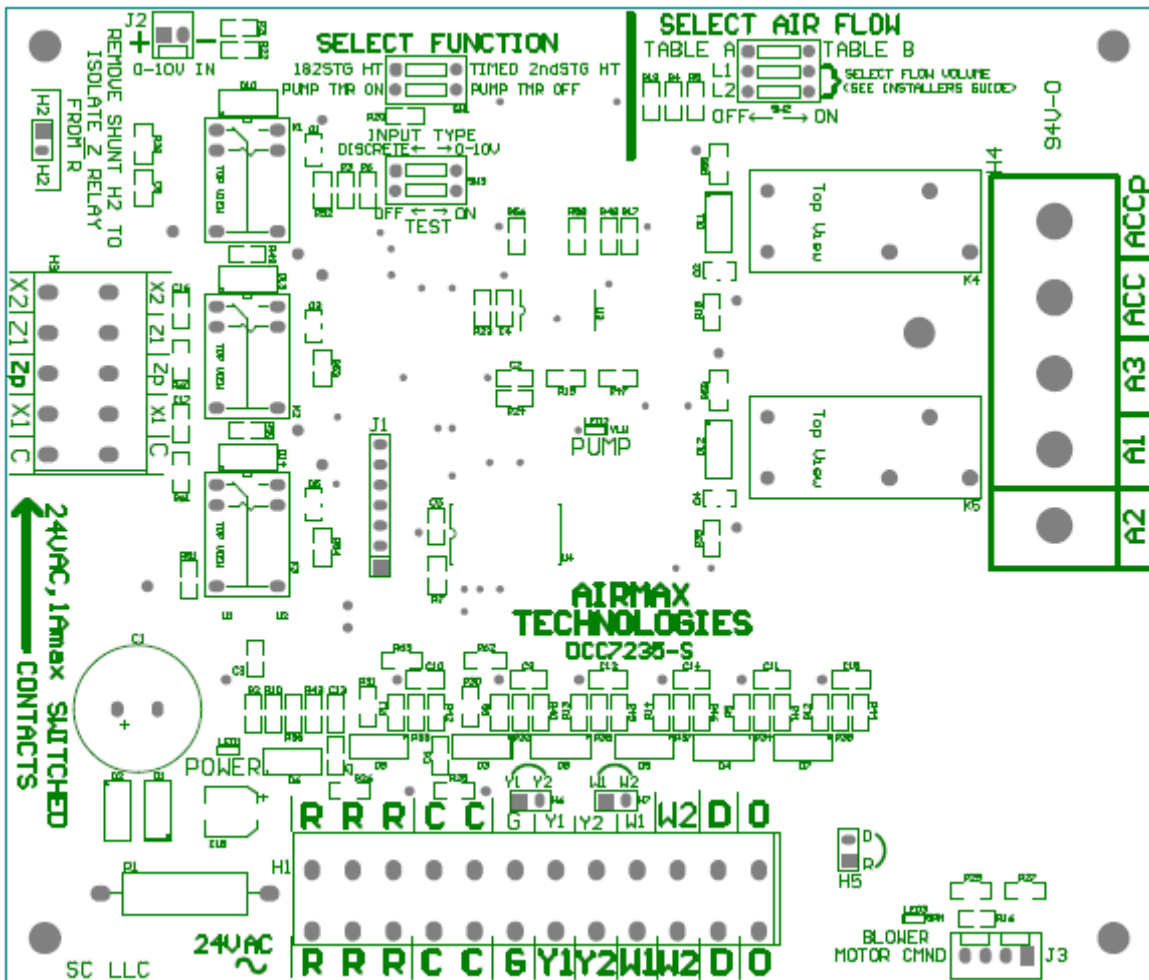

FIG 1

FIG 1

1. **POWER:**
 24VAC (nominal) supplied by a Class II transformer between terminals "R" ("24VAC LINE") and "C" ("24VAC RET"). The **RED "POWER" LED** illuminates when the control is powered.
 Transformer rating: 20VA minimum
 Voltage: 22.5Vac Minimum, 30Vac Maximum
 Current: <100ma (All outputs and relays active)
NOTE: SUPPLY 24VAC POWER FROM THE SECONDARY OF AN NEC CLASS-2 TRANSFORMER ONLY.
2. **CONTROL SYSTEM INPUTS**
 - a.) **0-10vdc Command** — When SW3-1 "TEST" is **ON**, a 0-10 VDC input to J2 between Vin+ and Vin- produces a variable PWM output of 0% through 100%. **The polarity of the input signal must be observed.** See Figs 1 & 2:
 - Differential Input Voltage: 0 V to 10 VDC represents 0 to 100% PWM
 - Maximum Input V dc: +10.2 Vdc
 - Common Mode Voltage: - 0.2 V max negative, +5 V max positive
 - Signal (differential) Input impedance: >150K Ohm (Vin+ to Vin-)
 - Common mode impedance: > 150K Ohm to COM

ON/OFF: ON = input VDC > 0.5VDC +/- 0.1V

OFF = input VDC < 0.4VDC +/- 0.1V

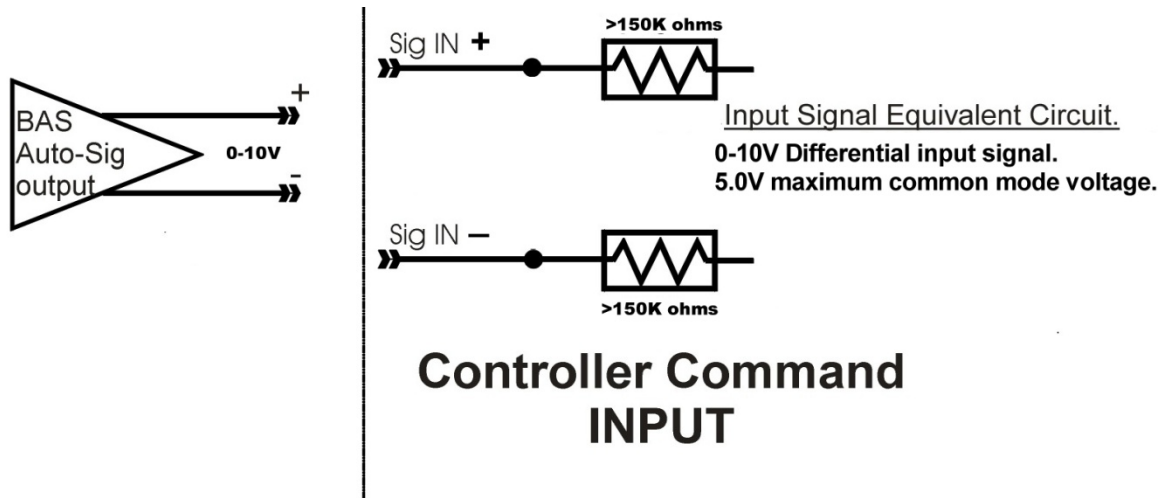

FIG 2

b.) Switched 24VAC INPUTS (SW3-1 IN "DISCRETE POSITION": (see para. 5.)

- G – Fan Only MODE
- Y2 & O & G – HIGH COOL MODE
- Y1 & O & G – LOW COOL MODE
- W1 – 1st STAGE HEAT MODE
- W2 – 2nd STAGE HEAT MODE
- Y1 & G & NOT O – Low Stage Heating (with Heat Pump)
- Y2 & G & NOT O – High Stage Heating (with Heat Pump)
- D – Accessory Control (Dehumidifier, Aquastat, etc). D is connected to "R" when shunt H5 is in place. Remove H5 to control the D terminal by an external switch.

b.1.) INPUTS SPECIFICATIONS

Input Impedance:

Y1 and Y2

~1K Ohm between: each terminal to C (24VAC Return).

Minimum acceptable cooling anticipator resistance: 3.3K Ohms between 24Vac(R) to Y1 or Y2

All other inputs:

>10K Ohm between each terminal and C (24VAC return).

Load Current FORM FACTOR – All Inputs: Positive Half-Wave (with respect to C (24VAC RTN))

MIN AND MAX INPUT VOLTAGE – All 24VAC Inputs:

Signals ACTIVE: 20VAC minimum. 30VAC Maximum; Current: <15ma @30VAC.

Signals INACTIVE: <4VAC (Current from any signal source, switch, and/or external snubbers must hold inputs to <4VAC or DC)

NOTE: DO NOT CONNECT THE SWITCHED 24VAC INPUTS FROM A 2nd, SEPARATE TRANSFORMER THAN THE 24VAC SOURCE SUPPLYING POWER TO THIS CONTROL UNLESS THE TRANSFORMER SUPPLYING THIS CONTROL AND THE 2ND TRANSFORMER ARE PHASED PROPERLY WITH THEIR COMMONS CONNECTED.

3. OUTPUTS

A. CONNECTIONS TO EC MOTOR (ECM): J3 PIN-OUTS (SEE FIG 3):

J5-pin-1: **START/STOP**: When the Blower motor is commanded to operate this signal enables motor operation. (Use is optional. Use if the system requires a separate enable.)

0VDC = not enabled, 22VDC (nom) = enabled
10ma maximum sourced current.

J5-pin-2: **COMMON** – J5 Outputs Common (to **isolated** common input(s) on motor/drive).
DO NOT CONNECT COMMON TO 24VAC RET

J5-pin-3: **PWM Motor Command**: 0% to 100% duty-cycle.

OFF: 0VDC (min). ON: 22VDC (peak). 10ma max sourced current.

When measured on a DC voltmeter, the signal level varies from 0VDC to ~22VDC max as the percent PWM duty cycle increases from 0 to 100%.

The **Green LED "BLWR CMND"** illuminates when the PWM command is active. Brightness increases with PWM duty cycle.

J5-pin-4: NO CONNECTION

B. HIGH VOLTAGE RELAY OUTPUTS:

a. A1, A2, A3 (PUMP) Relay (Formerly "WV RELAY")

Contacts A1 (NO), A2 (NC) to A3 (Pole): A3 is "Dry" and can be connected to an external voltage source for switching to A1, A2.

The WV Relay is energized under the following conditions:

- 1) SWITCH "PUMP TMR ON" POSITION, **AND**
- 2) Upon detecting a call for W1 or W2 (no delay) **OR**
- 3) If W1 or W2 was not active for 6 (or 24) consecutive powered hours.

The **green "W_TIMER" LED** illuminates when the PUMP relay is activated.

b. ACCESSORY Relay (ACC, ACCp):

Contact ACC (NO) connects to pole ACCp. These are DRY Contacts and can be connected to an external voltage source.

The Accessory relay is energized with "G". i.e. Any call from the thermostat **that includes** an active "G" signal energizes this relay.

c. MAXIMUM CONTACT RATINGS:

8A @120 VAC (resistive)

8A @ 240 VAC (resistive)

C. LOW VOLTAGES RELAY OUTPUTS:

All Three low voltage relay contacts are rated 1AMP maximum @ 30VAC maximum.

a. "X1" LOW STAGE "Y" RELAY (Contact X1):

- i. The LOW Stage Y relay activates upon detecting a call for "Y1" (with or without "O" active).
- ii. Upon activation, the X1 terminal connects to "R" (the 24VAC powering the DCC7235). **This relay is NOT DRY; i.e. its pole is permanently connected to "R".**

b. "X2" High Stage "Y" RELAY" (Contact X2):

- i. The HIGH Stage Y relay activates on a call for Y2 (with or without "O" active).
- ii. On activation, the X2 terminal connects to "R" (the 24VAC powering the DCC7235). **This relay is NOT DRY; i.e. its pole is permanently connected to "R".**

c. "Z" RELAY" (Contacts Z1, Z1p):

- i. The Z1 terminal switches to Zp on any "W" call (W1 or W2).
- ii. **As shipped, SHUNT H2 connects Zp to "R", i.e. THE W RELAY CONTACTS ARE NOT "DRY"**

AS SHIPPED. See

diagram below.

- iii. **WHEN H2 is removed** the contacts are "DRY" and be connected to a second, separate, isolated 24VAC power source. See diagram below.

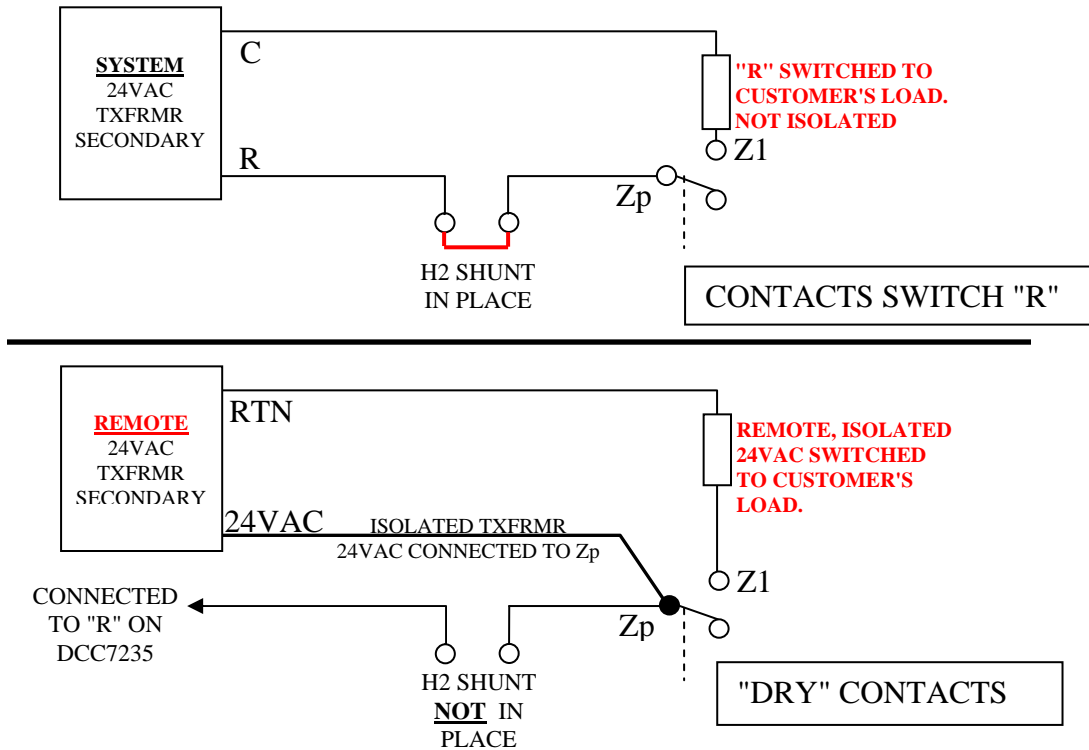

4. DIP-SWITCHES: FLOW VOLUME SELECT OPTIONS

a. DISCRETE/VARIABLE (0-10V) MODE INPUT SELECTOR (SW3-1)

1. **SW3-1 IN "DISCRETE" SWITCH POSITION: TABLE A-B PWM OUTPUT SIGNAL LEVEL SELECTOR:**

The switch labeled "TABLE A", "TABLE B" in combination with the switches labeled "L1" and "L2" select the flow levels for each of the discrete input states. Each Discrete input or combination of inputs activates a pre-programmed selection of customer-specified PWM duty-cycle output. The various combinations are used to operate equipment with different capacities. The selections are per in the tables below:

TABLE A (SW2-1) SWITCH "OFF" POSITION:







SET MAX AIRFLOW SEL 1&2	"L1,L2" SELECTIONS WITH DISCRETE INPUT <u>TABLE A</u> SELECTED							
	G _(ONLY)	Y2 & G & /O	Y1 & G & /O	Y2 & G & O	Y1 & G & O	W1 & D	W2 & D	(W1 or W2) & /D
L1, L2=0 	20%	100%	60%	100%	60%	50%	100%	20%
L1=1,L2=0 	20%	100%	60%	100%	60%	35%	83%	20%
L1=0,L2=1 	20%	83%	50%	83%	50%	35%	83%	20%
L1,L2=1 	20%	83%	50%	83%	50%	25%	50%	20%

TABLE B (SW2-1) SWITCH "ON" POSITION:

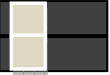
SET MAX AIRFLOW (Dip-SW2)	"L1,L2" SELECTIONS WITH DISCRETE INPUT <u>TABLE B</u> SELECTED							
	G _(ONLY)	Y2 & G & /O	Y1 & G & /O	Y2 & G & O	Y1 & G & O	W1 & D	W2 & D	(W1 or W2) & /D
L1, L2=0 	20%	66%	35%	66%	35%	35%	66%	20%
L1=1,L2=0 	20%	50%	25%	50%	25%	25%	50%	20%
L1=0,L2=1 	20%	35%	20%	35%	20%	20%	35%	20%
L1=1,L2=0 	20%	25%	20%	25%	20%	20%	25%	20%

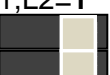
NOTE: TABLE A OR B AND SELECTIONS WITHIN TABLES A AND B BECOME EFFECTIVE WITHOUT CYCLING 24VAC POWER 2 TO 4 SECONDS AFTER CHANGING SWITCH POSITIONS.

2. **SW3-1 IN "0-10V IN" SWITCH POSITION:** Selects **CONTINUOUSLY VARIABLE** outputs per table 3, below and the command (volume) level is input via the "0-10V IN" connector:



L1,L2 SELECTIONS WHEN 0-10V INPUT ACTIVE		
SET MAX AIRFLOW (DIP-SW2)	COMMAND INPUT RANGE	COMMAND OUTPUT RANGE
L1,L2=0 	0-10V	0-100%
L1=1,L2=0 	0-10V	0-83%
L1=0,L2=1 	0-10V	0-66%
L1,L2=1 	0-10V	0-50%

TABLE3

NOTE: POWER TO THE CONTROLLER MUST BE CYCLED FOR THE DISCRETE OR 0-10V SWITCH STATE TO BE RECOGNIZED. THE SELECTED STATE BECOMES EFFECTIVE AFTER POWER IS RESTORED.

B. ONE AND TWO STAGE HEATING SYSTEM SELECTOR

1. **"1&2-STG HT" (SW1-1):** In this position, single-stage and true two-stage heat control from a thermostat is operational. The Heating inputs (W1, W2) will operate the system as follows:

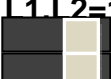
1. **OPERATING With a FURNACE ("Y" not Active in Heating)**

D & W1 active: When "1&2-Stg HT" and D AND W1 are active, the selected output PWM % shown under W1 in TABLES A and B, above, occurs after a 15 sec delay after any W activates.

D & W2 active: When "1&2-Stg HT" AND D AND W2 are active, the selected output PWM % shown under W2 in TABLES A and B occurs after a 15 sec time delay after W1 or W2 activate.

W2 has precedence over W1: If either W1 and W2, or W2 alone, is active, the W2 command output occurs.

STAGING DELAY: There is no time delay when sequentially staging from W1 to W2 or back (i.e. without an OFF-CYCLE).

For convenience, when a single stage HEAT system is applied, an on-board **SHUNT** connects W1 to W2 for operation at the W2 airflow whenever any W is active.

NOTE: THE SHUNT MUST BE REMOVED WHEN A TWO STAGE HEATING SYSTEM IS APPLIED.

When either or both W1 and W2 are active and D is NOT active, the output will be per the column (W1 or W2) & NOT D in Tables A and B.

2-stage WIRING: True 2-stage (2-wire: W1, W2) operation requires the W1 and W2 terminals of the thermostat to be wired to W1 and W2, respectively, on the DCC7235.

1-stage Wiring: Single stage operation can still be achieved by wiring only W1 from the thermostat to W1 of the DCC7235 for **LOW** airflow, or W2 from the thermostat to W2 of the DCC7235 for **HIGH** airflow. W1 and W2 can also be connected (jumpered) for HIGH Airflow in 1-stage systems.

For convenience, when a single stage system is applied, an on-board SHUNT connects Y1 to Y2 for operation at the Y2 airflow whenever any Y is active.

NOTE: THE SHUNT MUST BE REMOVED WHEN A TWO STAGE COMPRESSOR SYSTEM IS APPLIED FOR HEATING OR COOLING.

2. OPERATING with a HEAT PUMP ("Y" MUST BE Active for COMPRESSOR Heating)

D & W1 active: When "1&2-Stg HT" and **D AND W1** are active, the selected output PWM % shown under **W1** in the selected TABLE A and B, above, occurs after a 15 sec delay after any **W** first becomes active. A prior flow value (PWM%) selected by either **Y** will be replaced by the value selected by either **W**.

D & W2 active: When "1&2-Stg HT" and **D AND W2** are active, the selected output PWM % shown under **W2** in the selected TABLE A and B occurs after a 15 sec time delay after the first occurrence of **W1** or **W2**. A prior flow value (PWM%) selected by either **Y** will be replaced by the value selected by either **W**.

NOTE: WHEN EITHER OR BOTH W1 AND W2 ARE ACTIVE AND D IS NOT ACTIVE, THE OUTPUT WILL BE PER THE COLUMN (W1 OR W2) & NOT D IN TABLES A AND B.

2. "TIMED 2-STAGE HEAT" SWITCH (SW1-1) "ON"

1st stage -- D & W1 or D & W2 active: When the switch is in this position and either **W1 & D** or **W2 & D** are active, the volume command (PWM %) shown under **D & W1** in the selected TABLE A or B occurs after a 15 sec time delay from when W1 or W2 became active.

TIMED STAGING: When either **D & W1** or **D & W2** remain active for 5 minutes, the volume command (PWM %) transitions to the selected values shown under **D & W2** in the selected TABLE A or B, above, to give the high volume output.

When W1 or W2 is active and D is NOT active, the Output will be per the column (**W1 or W2**) & NOT D in Tables A and B.

TIMED STAGING WIRING: Either an energized W1 or W2 alone, or W1 and W2 together (for example, by connecting them together with an external shunt) will activate the timed 2-stage output.

NOTE: POWER TO THE CONTROLLER MUST BE CYCLED FOR THE 1&2-STG HT AND TIMED 2-STG HT SWITCH STATE TO BE RECOGNIZED. THE SELECTED STATE WILL BECOME EFFECTIVE AFTER POWER IS RESTORED.

C. PUMP TIMER RELAY ON-OFF (ENABLE/DISABLE)

- a. **"PUMP TMR ON":** The Pump RELAY Timer functions normally and will activate per paragraph B. a., above.
- b. **"PUMP TMR OFF":** The Pump RELAY Timer is disabled and will not activate.

D. NORMAL & TEST MODE TIMING (SW3-2 "TEST"):

NOTE: THIS SWITCH SELECTS NORMAL OPERATION OR THE TEST MODE

PUMP SWITCH (A1, A2, A3) TIMING AND FUNCTION LOCKOUT.

THE FOLLOWING DIAGRAM SHOWS THE TIMING OF THE PUMP RELAY. ITS OPERATES WITH THE TIMING AND BLOWER AND X1,X2 RELAY LOCKOUT PERIODS SHOWN.

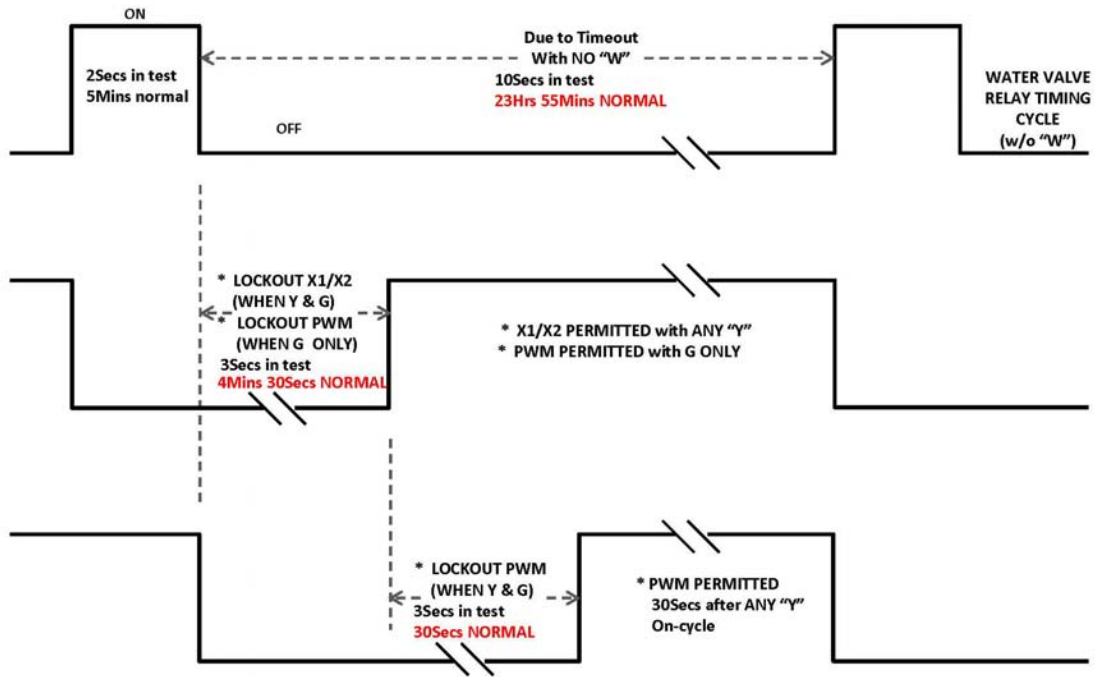

NOTE: POWER MUST BE CYCLED TO ENTER OR TO LEAVE THE TEST MODE. THE SELECTED STATE (TEST OR NORMAL OPERATION) BECOMES EFFECTIVE ONLY AFTER POWER IS RESTORED.

TYPICAL HOOKUP

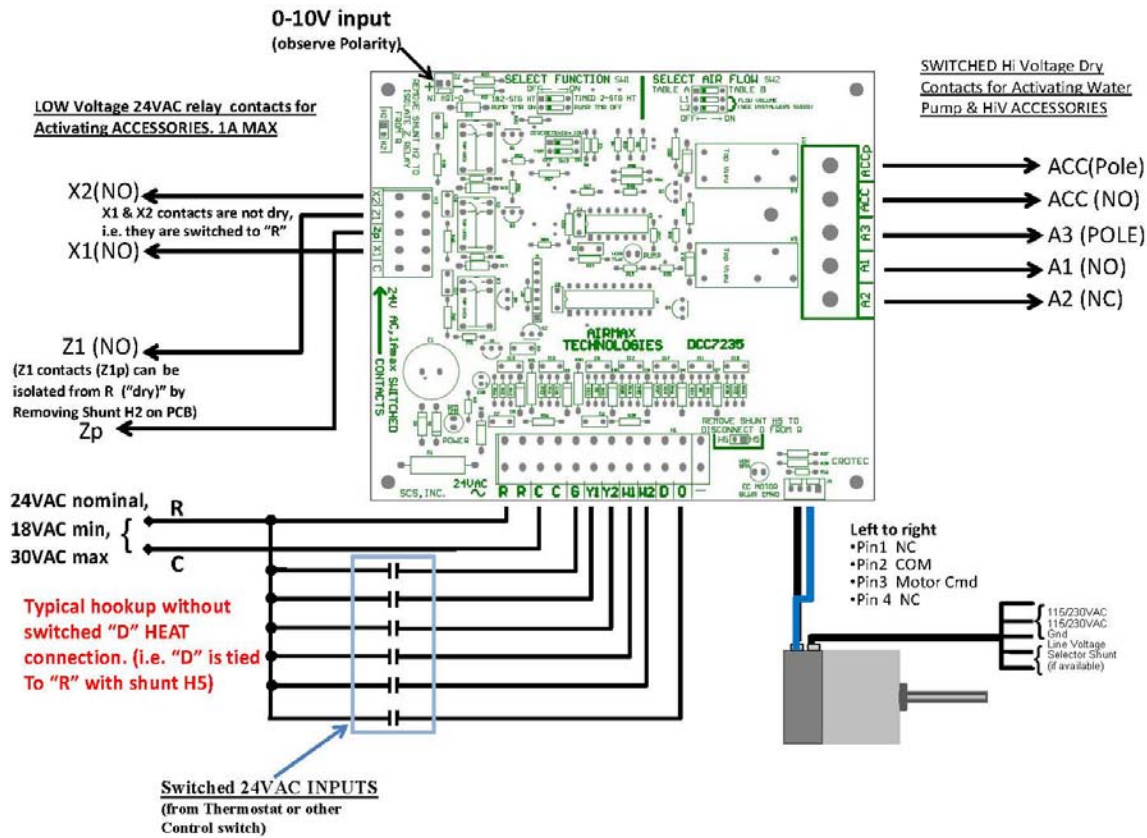

Confidential & Proprietary Information

FIG 3

5. DIMENSIONS and MOUNTING:

PC Board Dimensions: 4.8" x 5.66"

Mounting: 5 Nylon standoff snap-in feet

Hole centers: 4 at: corners spaced 4.5" x 5.26"

1 at: down 1.40", and in-board (left) 0.960" from center of top right corner standoff.

Recommended hole size: 0.191"

START-UP PROCEDURES

Do not start the air handler or water heater until ALL air has been purged!

by opening faucets at the remote parts of the plumbing system.

1. Fill the water heater or boiler, and or storage tank with water.
2. Purge all air for the domestic water lines

3. Purge all air from the space heating loop by closing the isolation valve on the return leg of the loop and open the drain to purge air. Open the return leg isolation valve and then close the drain valve. If no isolation valves are installed, open drain fully to purge air and let run for at least 30 seconds.
4. Start the water heater or boiler according to the manufacturer's instructions. Set the desired water temperature (140F/60C) and wait for the tank to shut off.
5. Turn on the power to the air handler and set the room thermostat for heat to energize the fan and pump. If a gurgling sound is present, it should subside within one minute. If noise is still present after one minute, repeat step 3 to purge air as necessary.
6. Grab hold of the heating lines with your hands to verify that they are getting warmer due to the hot water circulating through them. Also verify the circulating pump is operating by feeling for the vibrations. With the air handler running, ensure water flow through the circulation loop by measuring the water temperature difference. It should be in the range of 10-30°F temperature drop through the air handler with an entering water temperature between 135-180°F.

HINT: The temperature drop across the air handler can easily be measured with a probe type pocket thermometer. Wrap a rag or piece of insulation around the inlet and outlet of the heating coil to the air handler and insert the thermometer probe between the insulation and the pipe to take the reading. Wait at approximately 2 minutes to take each reading (*longer for systems with a storage*

tank). Make certain to take both readings one immediately after the other. At high flow rates the temperature in the tank may drift, causing error in the calculated temperature difference, if readings are taken more than 4 minutes apart.

Ensure that all electrical connections are tight, and that any packing or shipping restraints are removed from both the fan coil, and the condensing unit. With the power to the condensing unit off, check the thermostat for normal operation, and again check that there is proper airflow from all the vents. Ensure that no branch ducts were damaged or bent sharply. Do not run the fan coil without a filter in place.

DO NOT LEAVE THE SYSTEM UNATTENDED UNTIL NORMAL OPERATING CONDITIONS ARE OBTAINED.

Observe the condenser pressures during the initial start-up of the system. Check the voltage and amp draw of both the fan coil, and the outdoor condensing unit. The voltages must be within 10% of the rating plate data. If more than a 10% difference is noted, contact your local electrical company. Check that the amprage draws on both the air handler and condensing units are within the information printed on the unit rating plates. Set the refrigerant charge as required for optimal performance.

DO NOT USE THE FAN COIL FOR TEMPORARY HEAT DURING CONSTRUCTION. THIS WILL VOID ALL UNIT WARRANTIES

SEQUENCE OF OPERATION (STANDARD UNITS)

Refer to Ladder Diagram and Wiring Schematic for relay locations.

Note: **MaxAir™** air handlers are equipped

with 3 speed fan motors (high, medium, low). Speeds for heating, cooling and continuous run are all field selectable. Refer to *Electrical*

section for description.

Heating Cycle

1. Thermostat calls for heat, connection is made between the (“R” terminal) red and (“W” terminal) white thermostat wires.
2. Heating relay is energized; closes providing power to the heating speed motor tap; opens, interrupting power to continuous run motor tap. Pump relay is energized; A1 to A3 closes.
3. When room temperature is satisfied, thermostat breaks connection between red and white wires.
4. Relays are de-energized; pump stops, fan shuts off (or switches to continuous run speed when continuous run employed).

Cooling Cycle

1. Thermostat calls for cooling, connection is made between (“R” terminal) red and (“Y” terminal) yellow thermostat wires.
2. Cooling condenser circuit energized provided field supplied freeze thermostat is closed.
3. Connection is made between (“G”

terminal) green and (“R” terminal) red thermostat wire.

4. When thermostat satisfied, connection between red and yellow broken at thermostat.
5. Cooling condenser circuit is de-energized. Fan shuts off (or switches to continuous run speed when continuous run employed).

Continuous Run Cycle (Fan ON)

1. Connection is made between (“G” terminal) green and (“R” terminal) red thermostat wire.
2. Continuous run relay is energized; fan operates on continuous run speed. (factory set to high speed).

Continuous Run Cycle (full time)

1. Connection is made between F1 and F2 terminals on the board.
2. Fan operates on continuous run speed. (factory set to low speed).

SEQUENCE OF OPERATION (MAXe UNITS)

Refer to Ladder Diagram and Wiring Schematic for relay locations.

Note: **MaxAir™** air handlers are equipped with a brushless dc fan motor. Speeds for heating, cooling and continuous run are all field selectable. Refer to *Electrical* section for description.

Heating Cycle

1. Thermostat calls for heat, connection is made between the (“R” terminal) red and (“W1” and or “W2” terminal) thermostat wires as set up by installer.
2. Heating relay is energized; providing power to relay A1, circulating pump connection point. After “15 second delay” to allow plenum to warm up, Fan motor starts at value selected by installer and corresponding W1 or W2 input. If 2-stage timed heat is selected

at control board, fan speed will not increase to the “W2” value until after a programmed 5 minute delay

3. If R + D (optional aquastat circuit) are interrupted, motor remains at continuous low input value until circuit is made.
4. When room temperature is satisfied, thermostat breaks connection between “R” and “W1” / “W2” wires.
5. Relays are de-energized; pump stops, fan shuts off (or switches to continuous run speed when continuous run employed).

Cooling Cycle

1. Thermostat calls for cooling, connection is made between (“R” terminal) red (“G” terminal) green and (“Y1” or “Y2” terminal, factory bridged)

- thermostat wires, as selected by the installer.
- 2 Cooling condenser circuit energized provided field supplied freeze thermostat is closed.
 - 3 After Time delay fan motor starts at value selected by installer and corresponding "Y1" or "Y2" input
 - 4 When room temperature is satisfied, thermostat breaks connection between "R", "G" and "Y1" / "Y2" wires.

- 5 Cooling condenser circuit is de-energized. Fan shuts off (or switches to continuous run speed when continuous run employed).

Continuous Run Cycle (Fan ON)

- 1 Connection is made between ("G" terminal) green and ("R" terminal) red.
- 2 Continuous run relay is energized; fan input value operates on continuous run speed.

SERVICE AND MAINTENANCE

filter

The **MaxAir™** series air handlers are not provided with a filter. A good quality filter should be installed and or replaced or cleaned monthly.

A CLOGGED OR INADEQUATE FILTER MAY VOID PRODUCT WARRANTY.

duct cleaning

If proper filter maintenance is adhered to, duct cleaning is not required for the life of the equipment.

coils

Air conditioning and heating coils should not require cleaning if the filter maintenance schedule is adhered to. If a filter is damaged or collapses from plugging, the coils may get fouled by dust. If this happens, replace the filter and carefully vacuum the coils. The fan may need to be removed to gain access to the face of the heating coil.

air conditioning coil

At the start of each cooling season, check the

drain connection to the cooling coil to ensure it is free of debris. An easy way to do this is to blow into the tube to see if there is any obstruction. If a plugged air conditioning coil is suspected, call a service technician for testing and cleaning.

fan and motor

Check fan for dust once a year. If dirty, vacuum or wash to remove dust. Keeping the fan blades clean will reduce noise and improve the capacity and efficiency of the heating system. Take care to avoid wetting the motor! Remove the motor if required.

external pump

The circulating pump is water lubricated and should require no regular maintenance. If the pump fails to start at the beginning of the heating season, follow the instructions in the *Trouble Shooting* section of this manual below.

RUNNING THE PUMP WITH THE ISOLATION VALVES CLOSED OR WITH NO WATER IN THE SYSTEM WILL DAMAGE THE PUMP

NOTE: THE MAXAIR™ FAN COILS ARE NOT TO BE USED FOR TEMPORARY HEAT DURING CONSTRUCTION. USE FOR THIS PURPOSE WILL VOID EQUIPMENT WARRANTY.

TROUBLESHOOTING

external pump does not run

In areas where hard water is present the pump may “stick” and fail to run after long idle periods. Often this can be freed by closing the isolation valve on the return leg and opening the drain port so full city water pressure flows through the pump. If this fails to free the pump, removal for cleaning or replacement is necessary.

external pump is noisy at start-up

Air is present in heating loop. If sound has not diminished within 1 minute, purge air in accordance with the *Start-Up* procedures. Check to make sure branch connections for heating loop are horizontal.

water heater T&P is weeping

A check valve or back-flow preventor has been installed in the system. Some form of pressure relief may be required.

Options are:

- Install expansion tank.
- Install pressure relief valve; locate outlet over laundry tub or floor drain.

Install combination toilet tank/pressure relief valve

insufficient or no heat

- Plugged air filter or coil. Refer to *Maintenance* section for filter care and coil cleaning.
- Air in heating loop; purge system.
- Inlet and outlet connections to air handler backwards; reverse connections.

- Restricted or improperly installed supply tube in water heater; check and replace.
- Water heater thermostat set too low or not calibrated properly; check water temperature at a faucet. If the temperature has been set low because of homeowner preference, an anti-scald valve may be needed to provide the homeowner with the means of turning the domestic hot water down without affecting the heating output.
- Restriction in heating loop; remove restriction, check valve stuck or closed valve.

cold water at hot faucet

The most probable cause is reverse flow through the heating loop from a stuck check valve; repair or replace valve.

fan runs for cooling but not heating

Thermostat may be connected improperly. Refer to *Electrical* section for proper installation.

heating during off cycle

Probable cause is thermal siphoning. See check valve description for details; repair or replace check valve. Check elevation of air handler above water heater to see if motorized valve required for positive shut-off.

24 hr pump timer cycle is engaged. Wait to ensure pump shuts off after cycle is over (1m-15sec or 5min). Pump timer starts upon energizing of air handler with line voltage.

WIRING DIAGRAM (STANDARD UNITS)

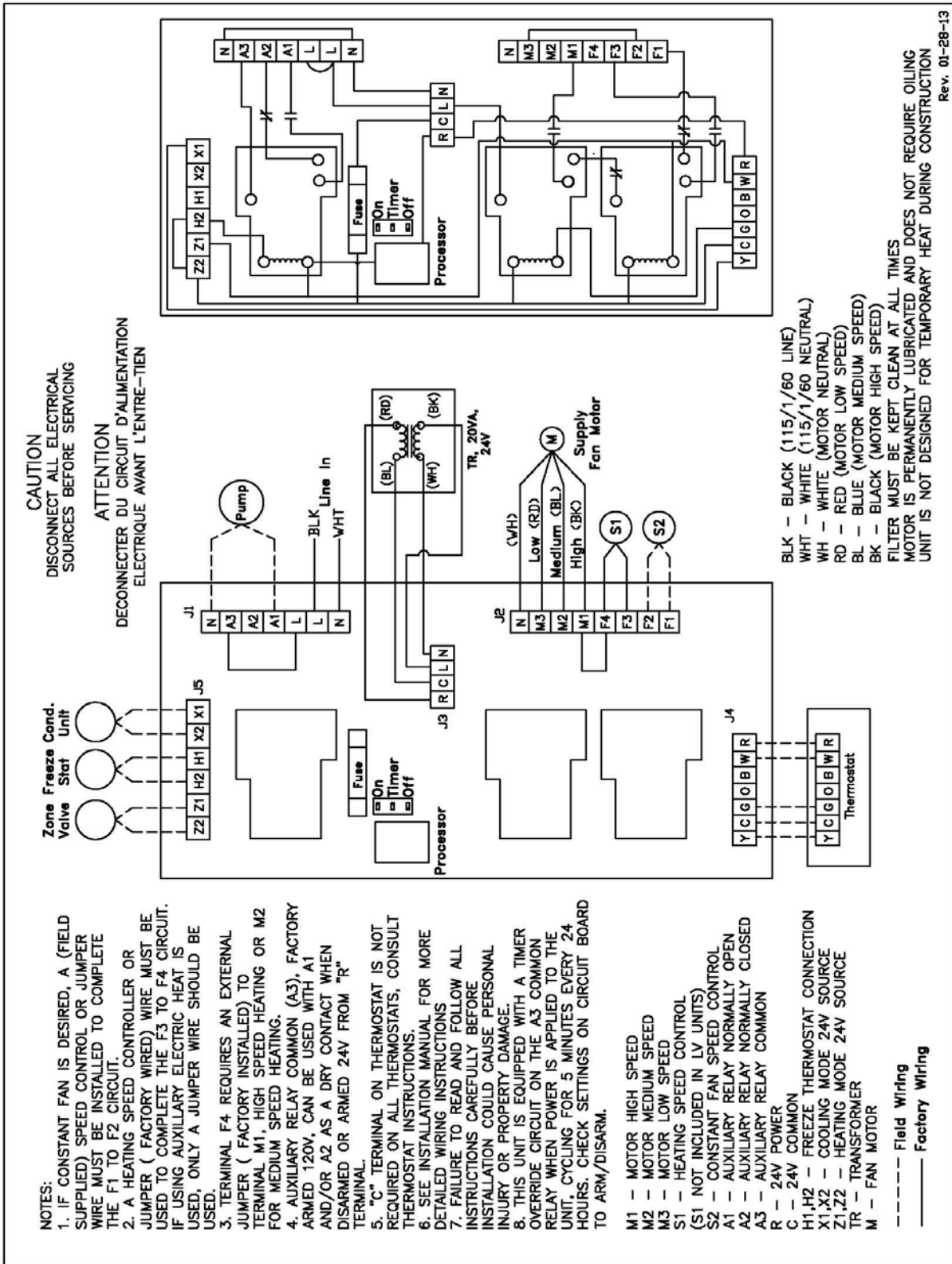

FAN COIL DIMENSIONS AND RETURN AIR SIZE & LOCATION

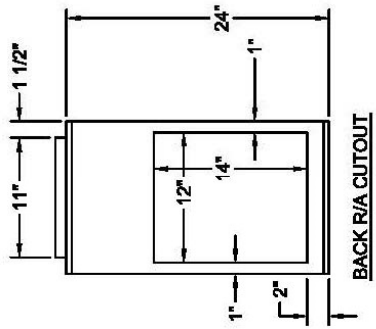

BACK R/A CUTOUT

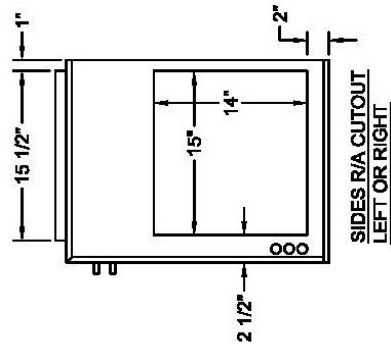

**SIDES R/A CUTOUT
LEFT OR RIGHT**

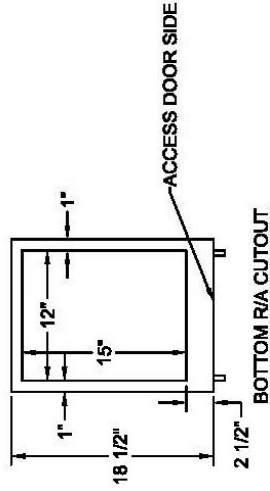
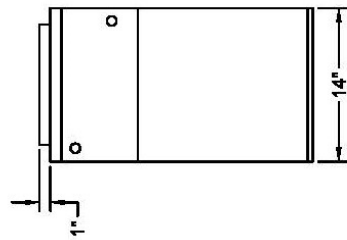

BOTTOM R/A CUTOUT

		Project MAXAIR 30(e) RETURN AIR CUTOUT	
		SIZE & LOCATION	
Equipment		Max 30(e)	Scale
Date		10/20/15	Drawn By
Drawing No.		50-081-001	NTS
		Qty.	

Revision	Revision Description	Approved By	Date

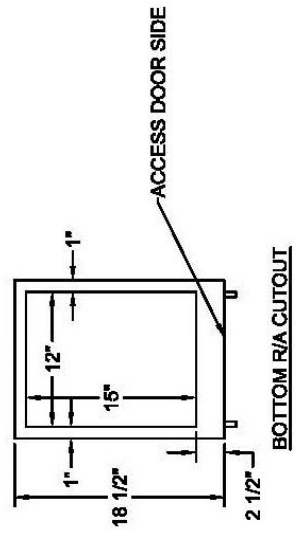
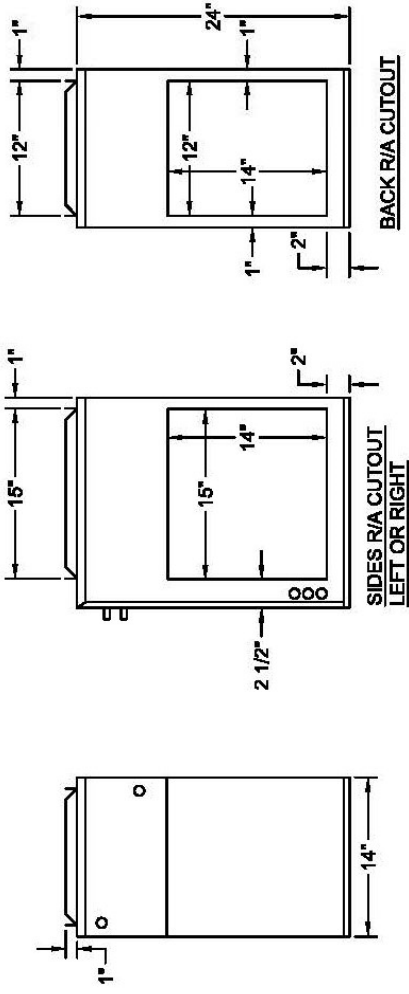

Remarks	Project MAXAIR 50(e) LV RETURN AIR CUTOUT SIZE & LOCATION		
Equipment	Max: 50(e) LV	Drawn By	Scale
		BTJ	NTS
	Date	Drawing No.	Qty.
	12/1/11	50-081-002	

Revision	Description	Approved By	Date

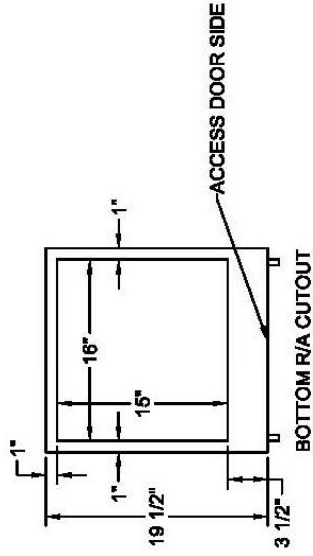
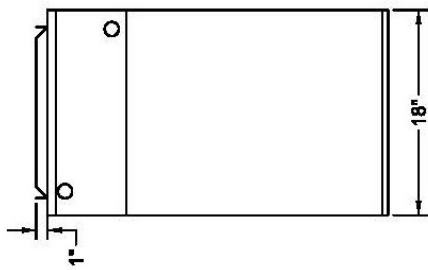
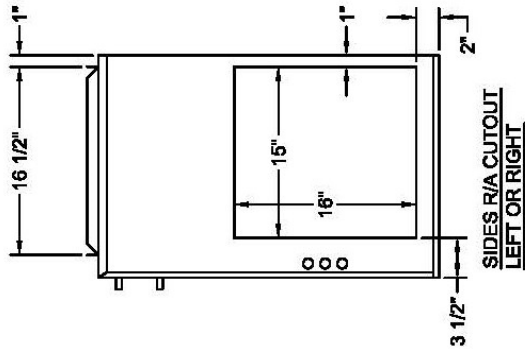
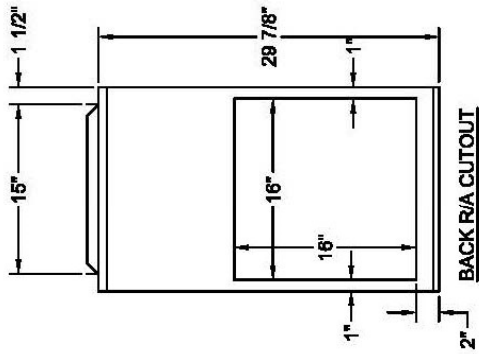

Project MAXAIR 70(e) LV RETURN AIR

Equipment
CUTOUT SIZE & LOCATION

Max 70(e) LV

Date 12/1/11
Drawing No. 70-081-002

Scale NTS
Drawn By BTJ
Qty.

Remarks

SEE ANGLE PROJECTION



Revision	Description	Approved By	Date

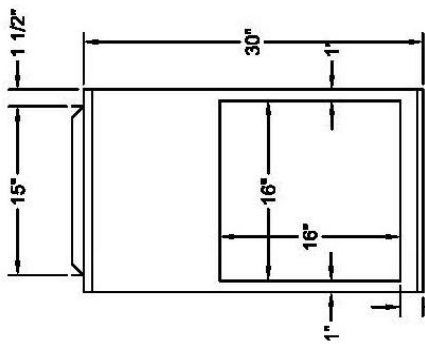

BACK R/A CUTOUT

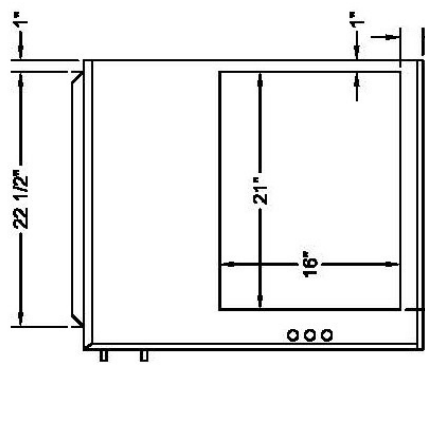

**SIDES R/A CUTOUT
LEFT OR RIGHT**

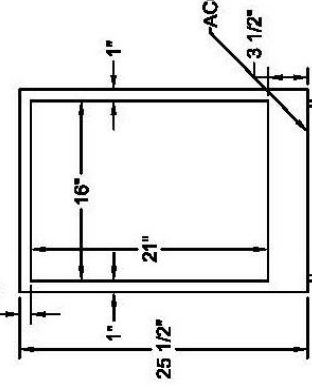
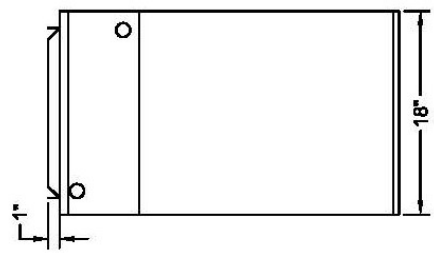

BOTTOM R/A CUTOUT



Project MAXAIR 100(e) LV RETURN AIR
CUTOUT SIZE & LOCATION

Equipment Max 100(e) LV

Date 12/1/11 Drawn By BTJ Scale NTS

Drawing No. 100-081-002 Qty.

Remarks



Revision	Revision Description	Approved By	Date

HORIZONTAL AIR FLOW EVAPORATOR COIL SIZES

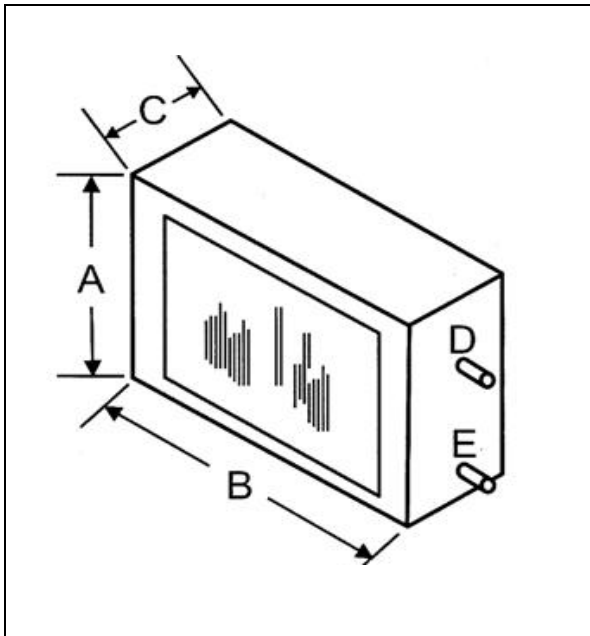

The coil module comes with a self adjusting thermal expansion valves (1T MA24-50-1– Metering device only), and an anti-ice control. The anti-ice control must be secured to the suction line as per instructions.

Note: All coils are to be sized to match the air handler.

COIL DIMENSIONS

Nominal Cooling Capacity	Model	Height (A)	Length (B)	Width (C)	Suction (D)	Liquid (E)	Weight (lbs.)	Nominal Cooling Airflow (cfm)	Coil Size
1 T	MA-24-50-1-R410-A	18"	19"	4.5"	3/4"	3/8"	15	400	11x16x2Rx10fpi
1 ½– 2 T	MA-24-50-R410-A	18"	19"	4.5"	3/4"	3/8"	15	600	11x16x4Rx10fpi
2 ½ T	MA-30-70-R410-A	18"	23"	4.5"	3/4"	3/8"	20	1000	15x16x4Rx10fpi
3 T	MA-36-100-R410-A	18"	23.5"	4.5"	3/4"	3/8"	25	1200	19x16x4Rx10fpi

All drains are ½" copper.

50/70/100 CCFF-001 COOLING COIL FILTER FRAME CABINET

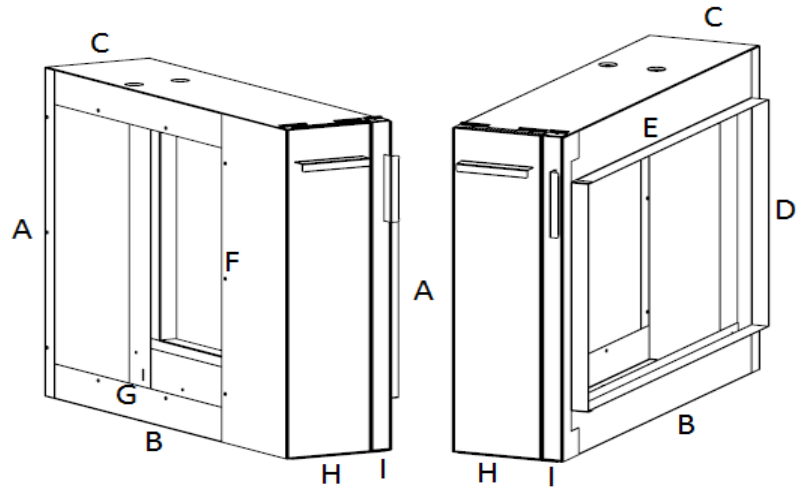

MODEL	A	B	C	D	E	F	G	H	I
50-CCFF-001	20"	20"	6 ¼"	14"	18"	15 ¾"	15"	5"	1 ¼"
70-CCFF-001	20"	25"	6 ¼"	14"	23"	15 ¾"	17 ¼"	5"	1 ¼"
100-CCFF-001	20"	25"	6 ¼"	14"	23"	15 ¾"	20 ¾"	5"	1 ¼"

Cooling Coil Filter Frame: Cooling coil filter frames accept a standard dimensional 1" filter. The coil section has dimples pressed into the top and bottom of the cabinet to ensure proper coil slope.

50-CCFF-001 cooling coil/filter frame 20" x 20" x 6-1/4" deep (accepts 16 x 20 x 1 filter), Return air connection is (14 x 18). Use with 30 & 50 series

70-CCFF-001 cooling coil/filter frame 20" x 25" x 6-1/4" deep (accepts 16 x 25 x 1 filter, Return air connection is (14 x 23). Use with 70 series

100-CCFF-001 cooling coil/filter frame 20" x 25" x 6-1/4" deep (accepts 16 x 25 x 1 filter, Return air connection is (14 x 23). Use with 100 series

SAMPLE PIPING SCHEMATICS

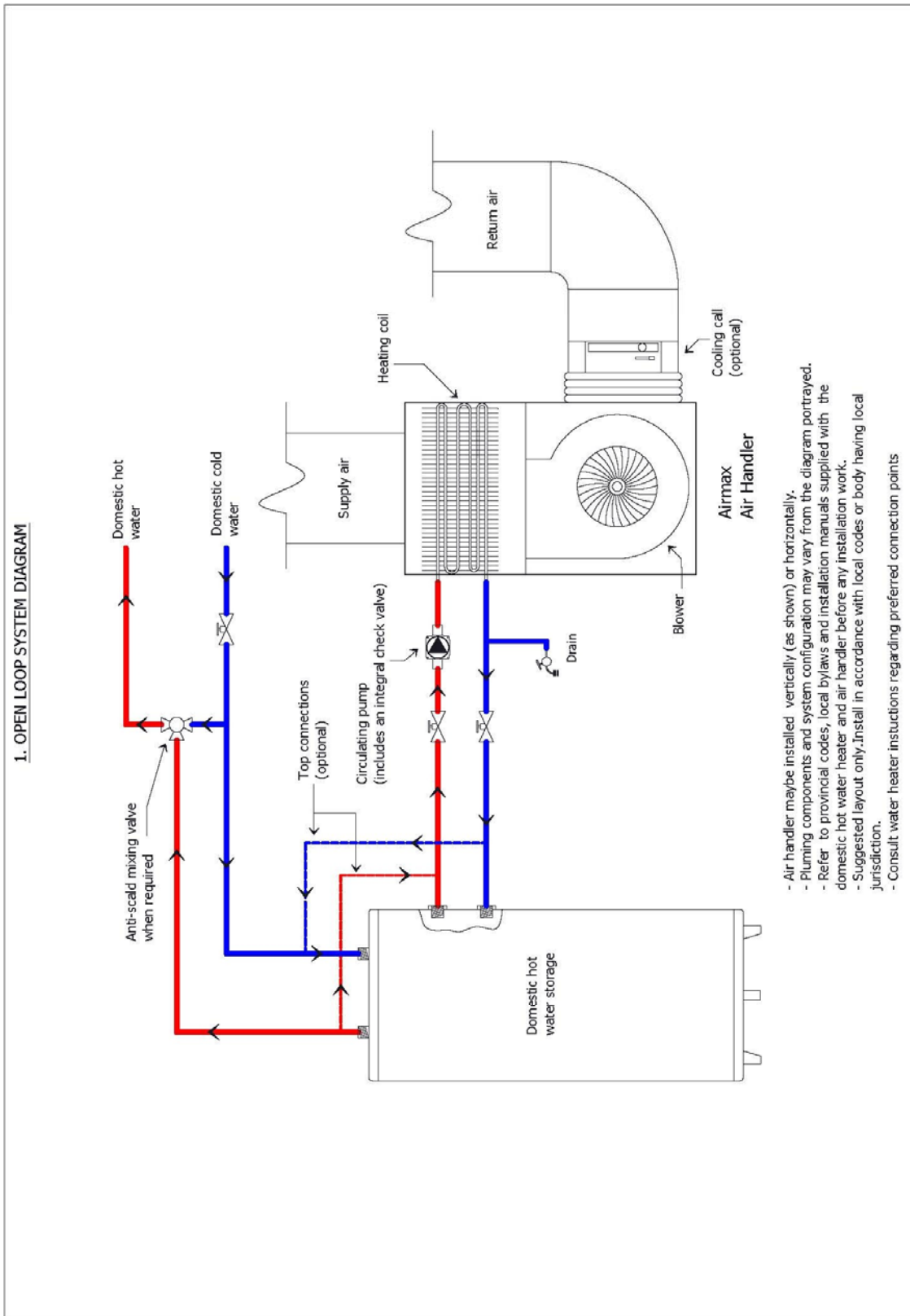

2. CLOSED LOOP SYSTEM DIAGRAM

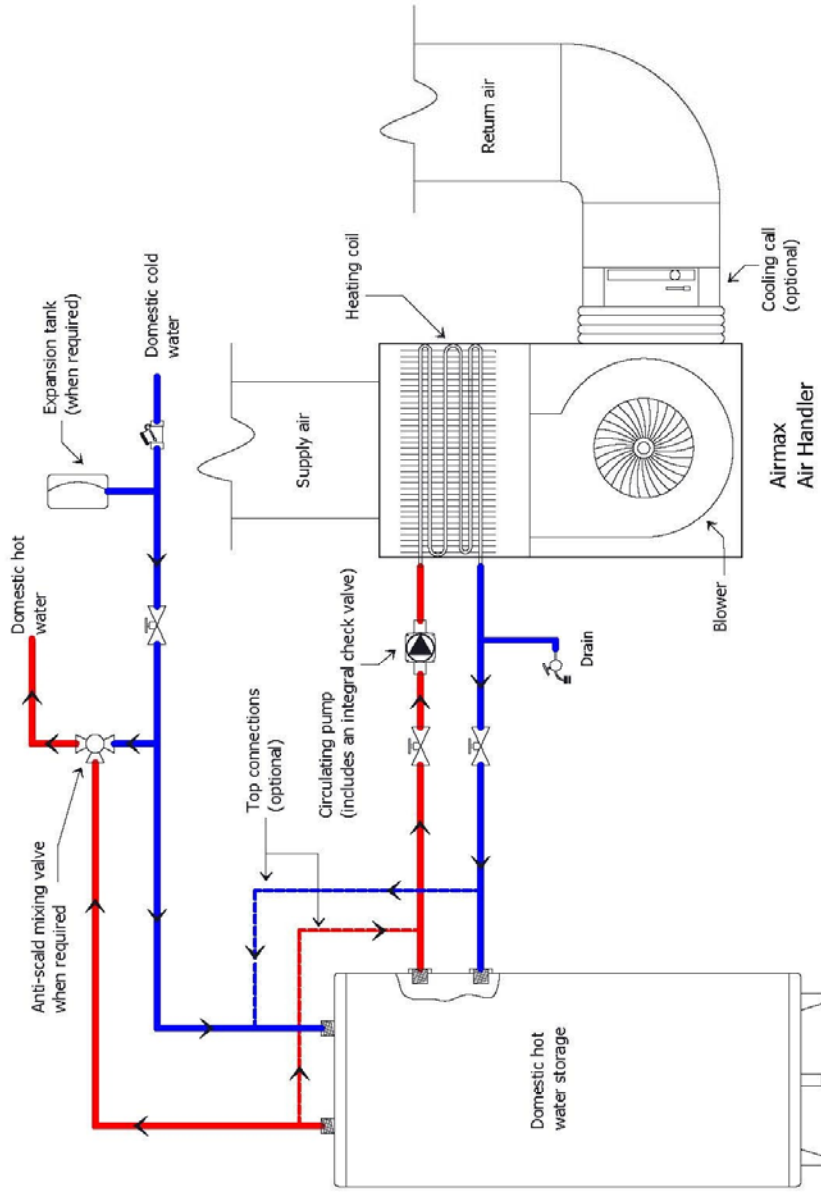

- Air handler maybe installed vertically (as shown) or horizontally.
- Plumbing components and system configuration may vary from the diagram portrayed.
- Refer to provincial codes, local bylaws and installation manuals supplied with the domestic hot water heater and air handler before any installation work.
- Suggested layout only. Install in accordance with local codes or body having local jurisdiction.
- Consult water heater instructions regarding preferred connection points



Terms and Conditions of Sale

E-mail: info@airmaxtechnologies.com
Web Site: www.airmaxtechnologies.com

- Warranty:** Warranty period is twelve (12) months from date of purchase. Warranty includes parts and labor (check with AirMax Technologies Inc. for labor allowance rates). An extended twelve (12) month warranty is available, where applicable, at an additional cost, please consult AirMax Technologies Inc. Cost of returning the goods to AirMax Technologies Inc. is \by others. All warranty parts are to be prepaid by the customer. No warranty will be in effect until the equipment is paid for in full. Warranty on all equipment sold to customer may be suspended, at AirMax Technologies Inc.'s disgression, until the customers account is in good standing. Warranty covers defective components only. Normal wear and abuse is not covered. The customer's account will be credited only after the defective part has been examined by AirMax Technologies Inc. or the vendor and determined to be defective.
- Claims:** Claims for damages and shortages must be made within two (2) days of receipt of goods. It is the responsibility of the receiving party to check count and condition of goods. The receiving party's signature on the shipping copy of the invoice or bill of lading absolves AirMax Technologies Inc. of responsibility for count and condition unless damage is concealed. In the case of damages or shortages, it is the responsibility of the receiving party to claim against the carrier if other than AirMax Technologies Inc.
- Returns:** Written permission must be obtained for return of all goods. All returns will be subject to a 25% restocking charge. All returns are to be prepaid. When returning goods, please quote the invoice number on which the goods were purchased, product serial number, and the return goods number issued by AirMax Technologies. Special or custom order equipment may not be returned for credit. Any products or components must be returned to AirMax Technologies Inc. free and clear of liens or other encumbrances.
- Limitations on Liability:** This warranty does not cover and no warranty is made with respect to;
- A. Failures not reported to AirMax Technologies within the time period specified above.
 - B. Failures or damage due to misapplication, misuse, abuse, improper storage, improper installation, or handling, abnormal conditions of temperature, water, dirt, corrosive substances, or other contaminants.
 - C. Products which have been repaired with parts or materials not furnished or approved by AirMax Technologies Inc. or by its authorized dealers or representatives, or products which have been in any way tampered with or altered.
 - D. Products damaged in shipment or storage or otherwise without fault of AirMax Technologies Inc..
- AirMax Technologies Inc.'s total responsibility for any claims, damages, losses, or liabilities related to the product covered hereunder shall not exceed the purchase price of such product. In no event shall AirMax Technologies Inc. be liable for any special, indirect, incidental, or consequential damages of any character, including but not limited to loss of productive facilities or equipment, delay of construction schedule, lost profits, property damage, transportation, installation or removal, lost production, or personal injury whether suffered by the purchaser or any third party. AirMax Technologies Inc. disclaims all liability for any and all costs, claims, demands, charges, expenses, or other damages, either direct or indirect, incidental to personal injury or property damage arising out of any cause of action based on strict liability.
- Freight:** Prepaid and bill, FOB Factory
- Payment Terms:** 2% 10 days. Net 30 days (O.A.C.). 2% service charge will be applied to overdue accounts.
- Taxes:** All taxes extra
- All prices, terms, and conditions are subject to change without notice.



Warranty Registration

E-mail: info@airmaxtechnologies.com
Web Site: www.airmaxtechnologies.com

PLEASE COMPLETE THE FOLLOWING INFORMATION AND RETURN WITHIN 30 DAYS OF THE UNIT START UP AND INCLUDE A COPY OF THE EQUIPMENT COMMISSION FORM FOR EACH PIECE OF EQUIPMENT.

Sold To:

Company Name _____

Contact Name _____

Address _____

City _____ State/Province _____ Zip/Postal Code _____

Phone No. _____ Fax _____

Item Purchased:

Unit Model _____ Serial No. _____

Date of Purchase _____ Date of Start up _____

Installer _____

Purchased From:

Company Name _____

Contact Name _____

Signature _____ Date _____

To insure your warranty protection, please complete and return this form to AirMax Technologies Inc. attention Product Registration.



Warranty Parts Request Form

E-mail: info@airmaxtechnologies.com
Web Site: www.airmaxtechnologies.com

Homeowner Name: _____ **Date:** _____

Address: _____ Unit # _____

City: _____ Prov. _____ Postal Code: _____

Phone # _____ Other # _____

Contractor Name: _____

Address: _____ Unit # _____

City: _____ Prov. _____ Postal Code: _____

Phone # _____ Other # _____

Email: _____

Distributor / Rental Provider Name: _____

Address: _____ Unit # _____

City: _____ Prov. _____ Postal Code: _____

Phone # _____ Other # _____

Email: _____

Model Number: _____ **Serial number:** _____

Date installed: _____ Date Failed: _____ Date Serviced: _____

Failed Part Number: _____ **Replacement Part Number:** _____

Failed Part Description: _____

Reason for Failure: _____

“FAILED, NOT WORKING, DEFECTIVE” etc. is not acceptable and will be considered incomplete. Incomplete warranty forms will not be accepted or considered; only a detailed explanation of the component failure will be considered for warranty.

All parts returned must be accompanied with a completed warranty tag.