

Comfortable Space Heating with a Hydronic Furnace



AIRMAX
TECHNOLOGIES

MAXAIR LV PRODUCT BENEFITS

MAX COMFORT

- Hydronic Heating using a hot water coil delivering comfortable, efficient heat to your home.
- Your home is less dry than a typical gas furnace.

MAX ENERGY SAVINGS

- Optional ultra high efficient electronic commutated motor (ECM) to produce constant air circulation using very little energy.
- Hydronic furnace requires no venting or gas lines with reduced installation costs.

MAX FLEXIBILITY

- Multi-position and flexible installation (basement, closet, crawl space or attic) used in new construction and retrofit applications.
- Can accommodate cooling, humidifiers, hrvs and whole house air cleaners while utilizing conventional ducting systems.
- Hydronic Air Handler can accommodate most brands of cooling coils and chilled water coils. This allows HVAC professionals to use the equipment of their choice.
- Must be matched with a dual purpose tankless hot water heater, boiler, water heater or heat pump.
- Three compact sizes ranging from 25,000 BTU to 153,590 BTU and from 1 to 4 tons of cooling.

PRODUCT PERFORMANCE RATINGS

MAXAIR Model	30 LV	30e LV	50 LV	50e LV	70 LV	70e LV	70e LV HO
Btuh Heating @180F E.W.T.	48,393	46,236	60,047	72,850	79,316	95,496	103,541
Btuh Heating @170F E.W.T.	43,938	41,983	54,496	66,085	71,780	86,566	93,833
Btuh Heating @160F E.W.T.	39,488	37,735	48,953	59,334	64,428	77,662	84,156
Btuh Heating @150F E.W.T.	35,045	33,492	43,422	52,601	57,098	68,790	74,518
Btuh Heating @140F E.W.T.	30,610	29,257	37,904	45,888	49,795	59,957	64,924
Btuh Heating @130F E.W.T.	26,186	25,031	32,404	39,202	42,523	51,169	55,386
DX Cooling (Tons) (1)	1	1	1 - 1½	1½ - 2	2	2 - 2½	2½ - 3
C.F.M. @ 0.5" E.S.P.	450	425	600	830	850	1,050	1,200
HP-RPM	¼ - 1.075	⅓ - 1.075	¼ - 1.075	½ - 1.075	⅓ - 1.075	½ - 1.075	¾ - 1.075
Amps @ 120/1/60	5.4	5.3	5.1	7.7	7.0	7.7	9.9
G.P.M. Flow Rating	5	5	5	5	7	7	7
Fan Coil Size (L/W/H)	24"x14"x18½"	24"x14"x18½"	24"x14"x18½"	24"x14"x18½"	30"x19½"x18"	30"x19½"x18"	30"x19½"x18"
Supply Air Size	11"x15½"	11"x15½"	11"x15½"	11"x15½"	15"x16½"	15"x16½"	15"x16½"
Return Air Size Required	12"x14" (min)	12"x14" (min)	12"x14" (min)	12"x14" (min)	16"x15" (min)	16"x15" (min)	16"x15" (min)

MAXAIR Model	100 LV	100e LV	100e LV HO
Btuh Heating @180F E.W.T.	122,103	136,268	153,390
Btuh Heating @170F E.W.T.	110,753	123,548	139,150
Btuh Heating @160F E.W.T.	99,427	110,862	124,941
Btuh Heating @150F E.W.T.	88,132	98,216	110,768
Btuh Heating @140F E.W.T.	76,875	85,621	99,791
Btuh Heating @130F E.W.T.	65,664	73,087	82,565
DX Cooling (Tons) (1)	3	4	4
C.F.M. @ 0.5" E.S.P.	1,300	1,700	1,600
HP-RPM	1 - 1.075	1 - 1.075	1 - 1.075
Amps @ 120/1/60	12.0	11.6	11.6
G.P.M. Flow Rating	8	8	8
Fan Coil Size (L/W/H)	30"x25½"x18"	30"x25½"x18"	30"x25½"x18"
Supply Air Size	15"x22½"	15"x22½"	15"x22½"
Return Air Size Required	16"x16" (min)	16"x16" (min)	16"x16" (min)

PRODUCT DIMENSIONS

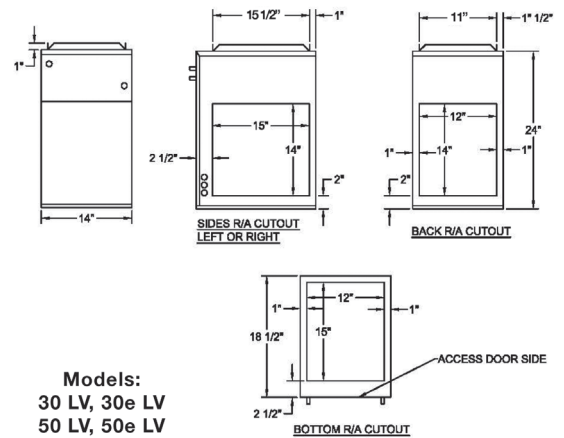

MAXAIR™ FLEXAIR™ are Trademarks of AIRMAX Technologies Inc.

© All rights reserved AIRMAX Technologies Inc.

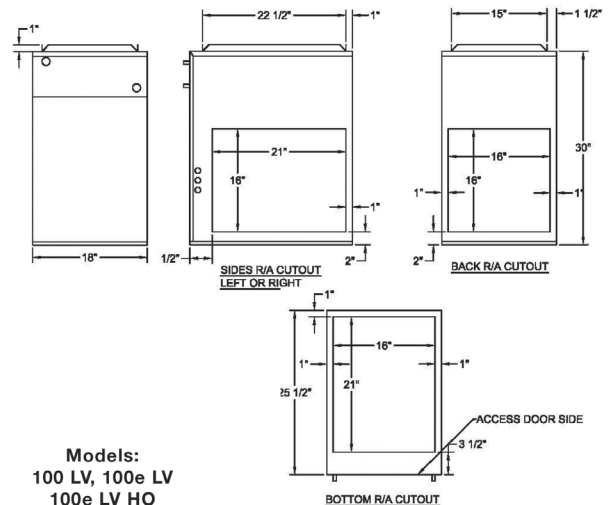
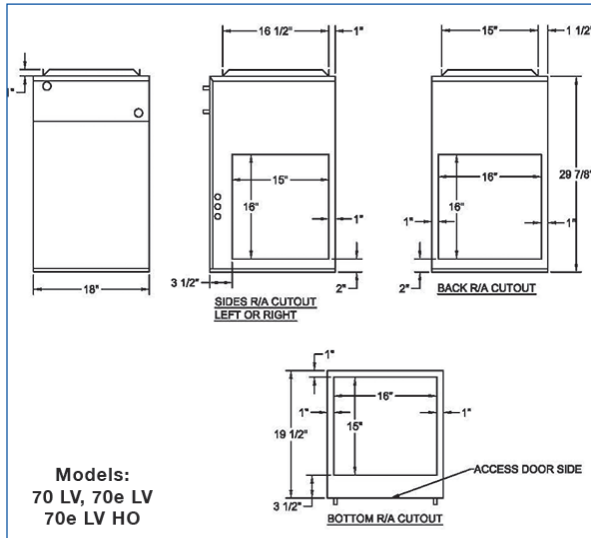

AIRMAX TECHNOLOGIES, 209 CITATION DRIVE, UNITS 5&6, CONCORD, ON, CANADA, L4K 2Y8

TELEPHONE (905) 264-1414 - FAX (905) 264-1147

E-MAIL: INFO@AIRMAXTECHNOLOGIES.COM - WEB SITE: WWW.AIRMAXTECHNOLOGIES.COM